

**Model 8000/8008**

**Modular Controller**

**User's Manual**



Certificate No.: FM 27207

Newport Corporation, Irvine, California, has been certified compliant with ISO 9002 by the British Standards Institution.



**Corporate Headquarters**  
Newport Corporation  
1791 Deere Avenue  
Irvine, CA 92714  
Telephone: 949-863-3144  
Facsimile: 949-253-1800  
**Belgium**  
Telephone: 016-402927  
Facsimile: 016-402227

**Canada**  
Telephone: 905-567-0390  
Facsimile: 905-567-0392  
**France**  
Telephone: 1-60 91 68 68  
Facsimile: 1-60 91 68 69  
**Germany**  
Telephone: 06151-36 21-0  
Facsimile: 06151-36 21-52

**Italy**  
Telephone: 02-924-5518  
Facsimile: 02-923-2448  
**Japan**  
Telephone: 03-5379-0261  
Facsimile: 03-5379-0155

**Netherlands**  
Telephone: 030-6592111  
Facsimile: 030-6570242  
**Switzerland**  
Telephone: 01-740-2283  
Facsimile: 01-740-2503

**Taiwon R.O.C.**  
Telephone: 2-2769-9796  
Facsimile: 2-2769-9638  
**United Kingdom**  
Telephone: 01635-521757  
Facsimile: 01635-521348

# Limited Warranty

Newport warrants that this product will be free from defects in materials and workmanship for a period of two years from the date of shipment. If any such product proves defective during the applicable warranty period, Newport, at its option, either will repair the defective product with charge for parts and labor or will provide a replacement in exchange for the defective product.

In order to obtain service under this warranty, the customer must notify Newport of the defect before the expiration of the warranty period and make suitable arrangements for the performance of service. In all cases the customer will be responsible for packaging and shipping the defective product back to the service center specified by Newport, with shipping charges prepaid. Newport shall pay for the return of the product to the customer if the shipment is within the continental United States, otherwise the customer shall be responsible for all shipping charges, insurance, duties and taxes, if the product is returned to any other location.

This warranty shall not apply to any defect, failure or damage caused by improper use or failure to observe proper operating procedures per the product specification or operators manual or improper or inadequate maintenance and care. Newport shall not be obligated to furnish service under this warranty 1) to repair damage resulting from attempts by personnel other than Newport's representatives to repair or service the product; 2) to repair damage resulting from improper use or connection to incompatible equipment; 3) to repair damage resulting from operation outside of the operating or environmental specifications of the product.

NEWPORT'S LIABILITY FOR THE MERCHANTABILITY AND USE OF THE PRODUCT IS EXPRESSLY LIMITED TO ITS WARRANTY SET OUT ABOVE. THIS DISCLAIMER AND LIMITED WARRANTY IS EXPRESSLY IN LIEU OF ANY AND ALL REPRESENTATIONS AND WARRANTIES EXPRESS OR IMPLIED, INCLUDING BUT NOT LIMITED TO, ANY IMPLIED WARRANTY OF MERCHANTABILITY OR OF FITNESS FOR PARTICULAR PURPOSE, WHETHER ARISING FROM STATUTE, COMMON LAW, CUSTOM OR OTHERWISE. THE REMEDY SET FORTH IN THIS DISCLAIMER AND LIMITED WARRANTY SHALL BE THE EXCLUSIVE REMEDIES AVAILABLE TO ANY PERSON. NEWPORT SHALL NOT BE LIABLE FOR ANY SPECIAL, DIRECT, INDIRECT, INCIDENTAL OR CONSEQUENTIAL DAMAGES RESULTING FROM THE USE OF THIS PRODUCT OR CAUSED BY THE DEFECT, FAILURE OR MALFUNCTION OF THIS PRODUCT, NOR ANY OTHER LOSSES OR INJURIES, WHETHER A CLAIM FOR SUCH DAMAGES, LOSSES OR INJURIES IS BASED UPON WARRANTY, CONTRACT, NEGLIGENCE, OR OTHERWISE. BY ACCEPTING DELIVERY OF THIS PRODUCT, THE PURCHASER EXPRESSLY WAIVES ALL OTHER SUCH POSSIBLE WARRANTIES, LIABILITIES AND REMEDIES. NEWPORT AND PURCHASER EXPRESSLY AGREE THAT THE SALE HEREUNDER IS FOR COMMERCIAL OR INDUSTRIAL USE ONLY AND NOT FOR CONSUMER USES AS DEFINED BY THE MAGNUSON-MOSS WARRANTY ACT OR SIMILAR STATE CONSUMER WARRANTY STATUTE.

©1995, 1996, Newport Corporation  
Irvine, California, USA  
Part No. 21281-01  
Rev. H



# EC DECLARATION OF CONFORMITY

## Model 8000/8008 Modular Controllers

We declare that the accompanying product, identified with the “**CE**” mark, meets all relevant requirements of Directive 89/336/EEC and Low Voltage Directive 73/23/EEC.

Compliance was demonstrated to the following specifications:

### EN50081-1 EMISSIONS:

Radiated and conducted emissions per EN55011, Group 1, Class A

### EN50082-1 IMMUNITY:

Electrostatic Discharge per IEC 1000-4-2, severity level 3

Rated Emission Immunity per IEC 1000-4-3, severity level 2

Fast Burst Transients per IEC 1000-4-4, severity level 3

Surge Immunity per IEC 1000-4-5, severity level 3

### IEC SAFETY:

Safety requirements for electrical equipment specified in IEC 1010-1.

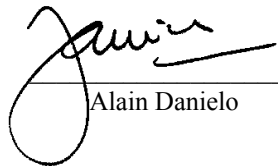

---

Alain Daniello

VP European Operations  
Zone Industrielle  
45340 Beaune-la-Rolande, France



---

Jeff Cannon

General Manager-Precision Systems  
1791 Deere Avenue  
Irvine, Ca. USA



# TABLE OF CONTENTS

<b>1. General Information</b>	<b>1</b>
<b>1.1 Introduction</b>	<b>1</b>
<b>1.2 Product Overview</b>	<b>1</b>
<b>1.3 Available Options and Accessories</b>	<b>4</b>
<b>1.4 Safety Terms and Symbols</b>	<b>5</b>
1.4.1 Terms	5
1.4.2 Symbols	6
<b>1.5 General Warnings and Cautions</b>	<b>6</b>
<b>2. System Operation</b>	<b>7</b>
<b>2.1 Introduction</b>	<b>7</b>
<b>2.2 Installation</b>	<b>7</b>
2.2.1 AC Power Considerations	7
2.2.2 Tilt-Foot Adjustment	8
2.2.3 Rack Mounting	8
2.2.4 Ventilation Requirements	8
2.2.5 Power-Up Sequence	8
<b>2.3 Introduction to the 8000 Front Panel</b>	<b>9</b>
2.3.1 Front Panel Familiarization	9
<b>2.4 General Operation</b>	<b>10</b>
2.4.1 Display Elements	10
2.4.2 Function Keys	12
2.4.3 Menu Structure	13
2.4.4 Master Display	14
2.4.5 Main Menu	15
2.4.6 Configure Menu	16
2.4.7 System Configure Screen	16
2.4.8 Save/Recall Screen	17
2.4.9 Linking Screen	19
2.4.10 Calibration Screen	20
2.4.11 Configure Communications Screen	20
<b>2.5 Rear Panel Familiarization</b>	<b>21</b>
2.5.1 GPIB Connector	21
2.5.2 RS-232 Connector	21
2.5.3 Input Power Connector	22
2.5.4 GND Post	22
<b>2.6 Power Supplies</b>	<b>22</b>
2.6.1 Module Power Supplies	22

2.6.2	Main Supply	23
<b>2.7</b>	<b>Warm Up and Environmental Consideration</b>	<b>23</b>
<b>3.</b>	<b><i>Laser Diode Driver Module Operation</i></b>	<b>25</b>
<b>3.1</b>	<b>Laser Diode Driver Module</b>	<b>25</b>
3.1.1	Introduction	25
3.1.2	Installation	25
3.1.3	Laser Diode Protection Requirements	26
<b>3.2</b>	<b>Laser Safety Features</b>	<b>28</b>
3.2.1	Conditions Which Can Automatically Shut Off the Laser Output.	28
3.2.2	Key switch Interlock	28
3.2.3	Turn On Delay	28
<b>3.3</b>	<b>The Laser Connectors</b>	<b>28</b>
3.3.1	Modulation	29
3.3.2	Photodiode Bias Control	30
3.3.3	Photodiode	30
3.3.4	Interlock	30
<b>3.4</b>	<b>Connecting to Your Laser</b>	<b>30</b>
3.4.1	Laser Diode Connections and Shielding	31
3.4.2	Photodiode Feedback Connections	32
3.4.3	Sync Out - Option	33
3.4.4	Grounding Consideration	33
<b>3.5</b>	<b>Laser Module Operation</b>	<b>33</b>
3.5.1	Quick Start	33
3.5.2	Laser Main Screen	34
3.5.3	Laser Setup Screen	35
3.5.4	Laser Modulation Setup Screen	37
3.5.5	Link Conditions	38
<b>3.6</b>	<b>Laser Module Theory of Operation</b>	<b>40</b>
3.6.1	Laser Interface	40
3.6.2	Limit DAC	40
3.6.3	Set Point DAC	41
3.6.4	A/D Converter	41
3.6.5	Current Source Voltage	41
3.6.6	Output Shorting	41
3.6.7	Modulation/Voltage Control Input Port	41
3.6.8	Photodiode Feedback Amplifier	41
3.6.9	Constant Current, High Bandwidth Mode	42
3.6.10	Constant Current, Low Bandwidth Mode	42
3.6.11	Constant Power Mode	43
3.6.12	Laser Interlock Operation	43
<b>4.</b>	<b><i>Temperature Controller Module Operation</i></b>	<b>45</b>



<b>4.1</b>	<b>Temperature Controller (TEC) Module</b>	<b>45</b>
4.1.1	Introduction	45
4.1.2	Installation	45
<b>4.2</b>	<b>TEC Safety Features</b>	<b>46</b>
4.2.1	Conditions Which Will Automatically Shut Off the TEC Output	46
<b>4.3</b>	<b>The TEC Connectors</b>	<b>46</b>
4.3.1	TEC Grounding Consideration	47
<b>4.4</b>	<b>TEC Module Operation</b>	<b>47</b>
4.4.1	Quick Start	47
4.4.2	TEC Main Screen	47
4.4.3	TEC Setup Screen	49
4.4.4	Link Conditions	52
<b>4.5</b>	<b>Sensors</b>	<b>53</b>
4.5.1	Thermistor and Thermistor Current Selection	53
4.5.2	AD590 and LM335	58
4.5.3	RTD Sensors	62
<b>4.6</b>	<b>TEC Module Theory of Operation</b>	<b>64</b>
4.6.1	TEC Interface	64
4.6.2	Limit DAC	64
4.6.3	Set Point DAC	65
4.6.4	A/D Converter	65
4.6.5	Sensor Select	65
4.6.6	Difference Amplifier	65
4.6.7	Proportional Amplifier and Integrator	65
4.6.8	Bipolar Output Stage	65
4.6.9	TEC Control Modes	66
<b>5.</b>	<b>Maintenance</b>	<b>69</b>
<b>5.1</b>	<b>Introduction</b>	<b>69</b>
<b>5.2</b>	<b>Fuse Replacement</b>	<b>69</b>
<b>5.3</b>	<b>Cleaning</b>	<b>69</b>
<b>6.</b>	<b>Calibration</b>	<b>71</b>
<b>6.1</b>	<b>Calibration Overview</b>	<b>71</b>
6.1.1	Environmental Conditions	71
6.1.2	Warm-Up	71
<b>6.2</b>	<b>Laser Calibration</b>	<b>71</b>
6.2.1	Recommended Equipment	71
6.2.2	Drive Current Load Resistor Selection	72
6.2.3	Local Operation Current Source (I <sub>o</sub> ) Calibration	72
6.2.4	Remote Operation Current Source (I <sub>o</sub> ) Calibration	73
6.2.5	Local Operation I <sub>PD</sub> Current Calibration	74

6.2.6	Remote Operation I <sub>PD</sub> Current Calibration	75
6.2.7	Local Operation Laser Voltage Measurement Calibration	76
6.2.8	Remote Operation Laser Voltage Measurement Calibration	77
<b>6.3</b>	<b>TEC Calibration</b>	<b>78</b>
6.3.1	Recommended Equipment	78
6.3.2	Local Operation Thermistor Calibration	79
6.3.3	Remote Operation Thermistor Calibration	79
6.3.4	Local Operation AD590 Sensor Calibration	80
6.3.5	Remote Operation AD590 Sensor Calibration	80
6.3.6	Local Operation LM335 Sensor Calibration	81
6.3.7	Remote Operation LM335 Sensor Calibration	81
6.3.8	Local Operation RTD Calibration	82
6.3.9	Remote Operation RTD Calibration	82
6.3.10	RTD Lead Resistance Calibration (Offset Null)	83
6.3.11	Local Operation ITE Current Calibration	83
6.3.12	Remote Operation ITE Current Calibration, Single Channel TEC Modules	84
6.3.13	Remote Operation ITE Current Readback Calibration, Dual and Combo TEC Modules	85
<b>7.</b>	<b>Factory Service</b>	<b>89</b>
7.1	Introduction	89
7.2	Obtaining Service	89
<b>8.</b>	<b>Error Messages</b>	<b>93</b>
8.1	Introduction	93
<b>9.</b>	<b>Specifications</b>	<b>97</b>
9.1	Model 8000 Modules	97
9.1.1	8540M MOPA Laser Diode Driver Module	97
9.1.2	Temperature Controller (TEC) / Dual (TEC) Module Specifications	98
9.1.3	Laser Diode Driver (LDD) Modules	100
9.1.4	Dual Laser Diode Driver (LDD) Modules	101
9.1.5	Combo Module, Laser Diode Driver (LDD) Section	102
9.2	Model 8008 Modules	105
9.2.1	Dual Laser Diode Driver (LDD) Modules	105
9.2.2	Combo Module, Laser Diode Driver (LDD) Section	106
9.3	Mainframe And General Specifications	109

## Tables

Table 1 - Laser Connector Pinouts	29
Table 2 - MOPA Laser Connector Pinouts	29
Table 3 - Laser Link Conditions	38
Table 4 - TEC Connector Pinouts	47
Table 5 - TEC Link Conditions	53
Table 6 - Comparison of Curve Fitting Equations	57
Table 7 - Thermistor Constants	58
Table 8 - RTD Constants	63
Table 9 - Recommended Test Equipment	71
Table 10 - Drive Current Load Resistor Selection	72
Table 11 - Recommended Test Equipment	78
Table 12 - Error Codes	93

## Figures

Figure 1 - 8000 Front Panel	9
Figure 2 - Various Data Fields Found on the Master Screen	12
Figure 3 - Model 8000 Menu Structure	13
Figure 4 - Master Display, Expanded Display	14
Figure 5 - Master Display, Condensed Mode	15
Figure 6 - Main Menu	16
Figure 7 - Configure System Screen	16
Figure 8 - Save/Recall Screen	18
Figure 9 - Link Screen	19
Figure 10 - Configure Communications Screen	20
Figure 11 - Rear Panel	21
Figure 12 - Power Supply Block Diagram	23
Figure 13 - Laser Diode Protection Circuit	27
Figure 14 - Common Laser Cathode / Photodiode Cathode	32
Figure 15 - Common Laser Cathode / Photodiode Anode	32
Figure 16 - Common Laser Anode / Photodiode Cathode	33
Figure 17 - Common Laser Anode / Photodiode Anode	33
Figure 18 - Laser Main Screen	34
Figure 19 - Laser Setup Screen	35
Figure 20 - Laser Module Block Diagram	40
Figure 21 - Constant Current - High Bandwidth Mode	42
Figure 22 - Constant Current - Low Bandwidth Mode	43
Figure 23 - Constant Power Mode	43
Figure 24 - TEC Main Screen	48
Figure 25 - TEC Setup Screen	49
Figure 26 - Thermistor Temperature Range	54
Figure 27 - Thermistor Resistance versus Temperature	57
Figure 28 - AD590 Nonlinearity	60
Figure 29 - TEC Board Module Diagram	64
Figure 30 - $I_{PD}$ Calibration Circuit	74



# 1. General Information

## 1.1 Introduction

---

This chapter describes the features, options, accessories, and specifications of the Model 8000.

Unless otherwise noted, “8000” or “Model 8000” refers to the Model 8000 and the Model 8008. Sections that deal with a specific model will be indicated as such.

## 1.2 Product Overview

---

### PRODUCT FEATURES

- Fully isolated module slots
  - Four in Model 8000, and eight in Model 8008
- GPIB/IEEE 488.2 and RS-232C Interface
- Link feature allows inter-module programming control not found in any other products.
- Temperature Controller (TEC) Module (8000 only)
  - 40 Watt (5A/8V), ultra stable bipolar output
  - Thermistor, AD590, LM335, and Pt RTD sensors
- Dual Temperature Controller Modules (8000 only)
  - Two independent outputs per module
  - 2.5 Amps at 6 Volts (15 Watt)
- Laser Diode Driver (LDD) Modules (8000 only)
  - 200 mA to 6 Amp low noise outputs
  - External analog modulation
  - Adjustable photodiode bias voltage
  - Comprehensive laser diode protection features
- MOPA Laser Diode Driver Module (8000 only)
  - 500 mA LDD for master oscillator section
  - 4 Amp LDD for power amplifier section
  - Connector for TEC module input
- Combination LDD/TEC Modules (8000)
  - Internal function generator
  - 2.5 Amps at 6 Volts (15 Watt) highly stable TEC
  - 200 mA to 2 Amp low noise LDD
- Dual Laser Diode Driver (LDD) Module (8000 and 8008)
  - Two independent outputs per module
  - 100 to 1,000 mA per channel
- Combination LDD/TEC Modules (8008)

- Internal function generator
- 2.0 Amps at 4 Volts (8 Watt) highly stable TEC
- 200 mA to 2 Amp low noise LDD

The Model 8000 Modular Controller is a result of Newport's continuing commitment to provide advanced laser diode instrumentation at affordable prices. The fully isolated bays are designed to accept a wide variety of modules.

Advanced designs guarantee that the Model 8000 will accommodate future modules making this controller the most complete instrument for laser diode control, characterization, and testing far into the future.

## **High Power Temperature Controller Fulfills All Your Thermo Electric (TE) Cooling Needs**

The 40 Watt Model 8350 Temperature Controller module is offered to meet your most demanding TE cooling needs. It may be operated in one of three modes:

- Constant Temperature
- Constant Resistance
- Constant TE Current

Short term stability is less than 0.004°C while long term stability is better than 0.01°C. Four sensor types are compatible with this TEC module:

- Thermistors
- AD590 series
- LM335 series
- 100Ω Platinum RTDs

With the sensor's calibration constants, the actual laser diode temperature is displayed in °C on the front panel.

## **Full Feature LDD Modules Offer Complete Test and Characterization Capabilities**

Advanced circuit designs and careful layout of 8500 series modules provide you with an extremely low noise, highly stable output current. Current outputs range from 200 mA to 6 Amps. An external analog modulation input allows precision control of the laser output for a variety of applications including power level control and wavelength tuning. A monitor photodiode may be zero biased for CW low noise applications or reversed biased up to 5 volts for high frequency modulation. All laser diode parameters are accessible with 16-bit resolution including the laser diode's forward voltage for full characterization using any of the 8500 series modules. Dual modules have all the same features except for external modulation and offer two independent channels in one module.

## **Combination LDD/TEC Modules Offer Full Laser Control In A Single Package**

When temperature stabilization is required, the 8600 series Combination LDD/TEC module gives you full control of your laser diodes. The TEC section temperature stabilizes your laser diode. On the LDD section, an internal function generator provides sine and square wave modulation.

## **Comprehensive Safety Features Protect Your Laser Diode**

Time tested laser diode protection safety features are incorporated into every Laser Diode Driver offered. Input power module filters provide first stage protection against transients. Additional filtering and power regulation stages coupled with high speed transient detection circuits let you operate your laser diode worry free from transients. A slow turn-on sequence, multiple output shorting circuits, and an independent current limiting feature provide the superior protection you demand from all your laser diode instrumentation.

## **Intuitive Controls and Large Graphics Display Simplify Control and Test Procedures**

Improved data presentation and system control are achieved using a large graphics display. A MASTER display shows the entire system configuration as well as each module's status. "Soft Keys" guide you through initial system setup routines and the operation of each module. Real-time control of an output is accomplished either by entering the set point on the keypad or via the control knob. MENU and FUNC keys access saved system configurations and repetitive procedures. All controls are clearly marked and instructions easily understood for simple operation.

## **GPIB/IEEE-488.2 and RS232 Interfaces Gives Power to Remotely Control and Collect Data.**

For ultimate control a GPIB/IEEE-488.2 interface is available. All control and measurement functions are accessible via the GPIB interface. In addition, standard serial RS-232C input and output ports allow several of the mainframes to be connected together to build large test and characterization stations. As your instrumentation needs change the Model 8000 Modular Controller will adapt to all your new laser diode applications giving you the ultimate in flexible laboratory equipment.

### 1.3 Available Options and Accessories

---

Model 8000 Modular Controller Mainframe<sup>1</sup>

Model 8008 Modular Controller Mainframe<sup>1</sup>

Model 8000 MOPA Module

8540M 500 mA/4A Laser Diode Driver Module

Model 8000 Temperature Controller (TEC) Module

8325D 2.5A/6V 15W Dual Temperature Controller Module

8350 5A/8V 40W Temperature Controller Module

Model 8000 Laser Diode Driver (LDD) Modules

8505 500 mA Laser Diode Driver Module

8510 1,000 mA Laser Diode Driver Module

8530 3,000 mA Laser Diode Driver Module

8560 6,000 mA Laser Diode Driver Module

Model 8000 Dual LDD Modules

8501D 100 mA Dual Laser Diode Driver Module

8505D 500 mA Dual Laser Diode Driver Module

8510D 1,000 mA Dual Laser Diode Driver Module

Model 8000 Combination LDD/TEC Modules

8605 500 mA LDD & 2.5A/6V TEC Combination Module

8610 1,000 mA LDD & 2.5A/6V TEC Combination Module

8630 3,000 mA LDD & 2.5A/6V TEC Combination Module

Model 8008 Dual LDD Modules

8501.8D 100 mA Dual Laser Diode Driver Module

8505.8D 500 mA Dual Laser Diode Driver Module

8510.8D 1,000 mA Dual Laser Diode Driver Module

Model 8008 Combination LDD/TEC Modules

8601.8C 100 mA LDD & 2A/4V TEC Combination Module

8605.8C 500 mA LDD & 2A/4V TEC Combination Module

8610.8C 1,000 mA LDD & 2A/4V TEC Combination Module

---

<sup>1</sup> Blank plates provided with Mainframe Controller to cover unused bays.



**Accessories**

300-02	Temperature Controller Cable
300-04	Temperature Controller/Mount Cable
300-16	10.0 k $\Omega$ thermistor ( $\pm 0.2^{\circ}\text{C}$ )
300-22	AD592CN IC Sensor
300-30	LM335AZ IC Sensor
500-02	Laser Diode Driver Cable
500-04	Laser Diode Driver/Mount Cable
800-RACK	Rack Mount Kit
8008-RACK	Rack Mount Kit

Newport Corporation also supplies temperature controlled mounts, lenses, and other accessories. Please consult with your representative for additional information.

---

## 1.4 Safety Terms and Symbols

### 1.4.1 Terms

The following safety terms are used in this manual:

The **WARNING** heading in this manual explains dangers that could result in personal injury or death.

The **CAUTION** heading in this manual explains hazards that could damage the instrument.

In addition, a **NOTES** heading gives information to the user that may be beneficial in the use of this instrument.

## 1.4.2 Symbols

The following symbols are used in this manual and on the instrument:



Refer to the documentation.



Earth Ground

## 1.5 General Warnings and Cautions

---

The following general warning and cautions are applicable to this instrument:

### WARNING

This instrument is intended for use by qualified personnel who recognize shock hazards or laser hazards and are familiar with safety precautions required to avoid possible injury. Read the instruction manual thoroughly before using, to become familiar with the instrument's operations and capabilities.

### WARNING

The American National Safety Institute (ANSI) states that a shock hazard exists when probes or sensors are exposed to voltage levels greater than 42 VDC or 42V peak AC. Do not exceed 42V between any portion of the Model 8000 (or any attached detector or probe) and earth ground or a shock hazard will result.

### CAUTION

There are no serviceable parts inside the Model 8000. Work performed by persons not authorized by Newport Corporation may void the warranty. For instructions on obtaining warranty repair or service please refer to Chapter 7 of this manual.

## 2. System Operation

### 2.1 Introduction

---

This chapter describes how to operate the 8000 mainframe. Module specific details can be found in the module's manual.

### 2.2 Installation

---

**CAUTION**

Although ESD protection is designed into the 8000, operation in a static-free work area is recommended.

**CAUTION**

Do not plug-in or unplug a module with the AC power on.

#### 2.2.1 AC Power Considerations

The 8000 can be configured to operate at a nominal line voltage of 100, 120, 220, or 240 VAC. Normally, this is done at the factory and need not be changed before operating the instrument. However, be sure that the voltage setting is correct on the power input module and correct fuses are installed per section 5.2 before connecting to an AC source. The 8000 is shipped set for 120 VAC and a caution sticker is placed on the input power connector.

**CAUTION**

Do not exceed 250 VAC on the line input.

Do not operate with a line voltage that is not within  $\pm 10\%$  of the line setting. Too low of an input voltage may cause excessive ripple on the DC supplies. Too high of an input voltage will cause excessive heating.

**WARNING**

To avoid electrical shock hazard, connect the instrument to properly earth-grounded, 3-prong receptacles only. Failure to observe this precaution can result in severe injury or death.

### **2.2.2 Tilt-Foot Adjustment**

The 8000 has front legs that extend to make it easier to view the LED displays. To use them, place the 8000 on a stable base and rotate the legs downward until they lock into position.

### **2.2.3 Rack Mounting**

The 8000 may be rack mounted by using a 8000 rack mount kit. All rack mount accessory kits contain detailed mounting instructions.

### **2.2.4 Ventilation Requirements**

Rear panel area needs 2 to 4 inches of clearance for air circulation.

### **2.2.5 Power-Up Sequence**

With the 8000 connected to an AC power source, set the power switch to “**I**” or ON to supply power to the instrument and start the power-up sequence.

During the power-up sequence, the following takes place. For between 15 to 20 seconds an initialization screen is displayed. The software version is displayed in the lower left corner of the screen. During this time a self-test is performed to ensure that the 8000 hardware and software are communicating. If the 8000 cannot successfully complete this test, an error message will be displayed.

After this test, the 8000 is configured to the state it was in when the power was last shut off and displays the master display.

## 2.3 Introduction to the 8000 Front Panel

### 2.3.1 Front Panel Familiarization

Described below are the functions of each area of the front panel, as shown in Figure 1.

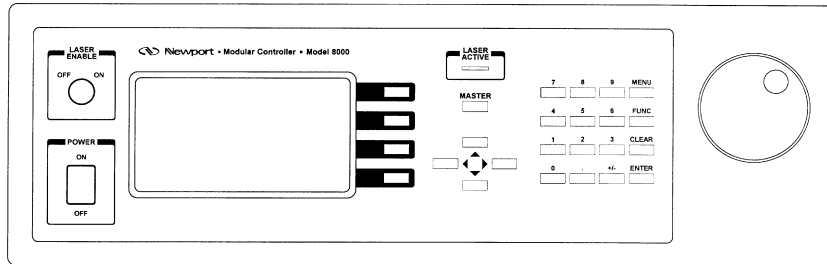

Figure 1 - 8000 Front Panel

1. **Power On/Off Switch** - Switches on/off the AC power to the unit.
2. **Laser Enable On/Off Switch** - Safety key-switch that enables/disables all laser outputs. See sections 3.6.12 and 3.3.4 for additional information on laser interlock.
3. **Laser Active LED** - Indicates one or more laser outputs are on.
4. **Display Soft Keys** - These are the four dark keys located to the right of the display. The function of these four keys varies depending on what menu is displayed. See section 2.4.1.4 for a complete description of soft keys.
5. **MASTER Key** - switches to the master display from any screen in the system (see section 2.4.2).
6. **Cursor Control Keys** - Moves cursor up or down between editable data fields. The left arrow functions as a backspace in numerical entry fields, or as a previous choice in a multi-choice entry field. The right arrow functions as a next choice in multi-choice entry fields. See section 2.4.1.3 for a description of data fields.
7. **Numerical Keys** - Used to set parameter values of numerical entry fields in various screens.
8. **MENU Key** - Switches to the main menu from any screen in the system (see section 2.4.2).
9. **FUNCTION Key** - Used to execute user macros and special functions (see section 2.4.2).
10. **CLEAR Key** - Clears numeric data typed, but not yet entered, in an edit field.
11. **ENTER Key** - Used to enter parameter values set with the numerical or left/right arrow keys.

12. **Knob** - Used to continuously vary certain parameters. The knob has an acceleration factor that causes the rate of change to increase as the knob is turned faster. Turning slowly allows for a fine adjustment at the smallest displayed decimal place.

---

## 2.4 General Operation

---

### 2.4.1 Display Elements

The Model 8000 uses a graphical display to depict information about the current state of the system. The display can be broken down into four basic elements: static fields, non-editable data fields, editable data fields, and soft key labels.

#### 2.4.1.1 Static Fields

Static fields are elements on the display which do not change from moment to moment. These can include help text, screen titles, and error messages.

#### 2.4.1.2 Non-Editable Data Fields

Non-editable data fields are used mainly to display read back information, such as temperature, laser current, etc. These fields can have a prefix or suffix label, such as “**I<sub>o</sub>**” or “**mA**”, and are periodically updated by the system.

#### 2.4.1.3 Editable Data Fields

Editable data fields are used for module and system settings such as current set point, temperature set point, display contrast, etc. An editable field has four distinct display states: focused, focused and editing, non-focused, and read-only.

The focused state indicates that the field has the input “focus.” When the a field has the focus, it is shown in reverse color (white text on black background if the display is not inverted). Any keyboard entry or knob adjustment will be applied to the field, and only one field at a time on the display can have focus. Move between fields using the up and down arrow keys.

When the user starts to make changes to the data field using the numeric or left/right arrows, the field enters the focused and editing state. In this state, a box is drawn around the data field to indicate changes are being made to the value. See section 2.4.1.3.1 below for a description of how the keyboard operates while in this state. The box will remain around the field until **Enter** or **Clear** is pressed, or the user moves focus to another field using the up or down arrows.

The non-focused state indicates that the field is editable, but does not currently have the focus. These fields are drawn with a solid underline. Using the up and down arrows, focus can be moved to these fields.

When the editable data field is in the read-only state, it looks and acts exactly like a non-editable data field. Like the non-editable data field, it cannot have focus, and the up or down arrow keys will skip over the field. This state is used primarily to lockout specific data elements from front panel change when the Model 8000 is in remote mode. Any IEEE-488 or RS-232 communication will place the unit in remote mode, and editable fields that are protected during remote operations change to the read only state.

#### 2.4.1.3.1 Changing Data Fields

A data field can only be changed from the front panel when the field has the focus. Some fields are numeric-based, such as current set point or temperature limits. Other fields are multi-choice fields, such as Yes/No fields. Both types are changed with the left and right arrows or the knob. Below is a description of each of the keys used for front panel input.

Perhaps the most important key is the **Enter** key. Any changes to a data field made with the numeric pad or left/right arrows are not put into effect *until the enter key is pressed*. It is a common mistake to type in a number and press the up or down arrow to move to the next field or change to another screen without first pressing **Enter** to store the new value. If focus is removed from the field before the **Enter** key is pressed, it reverts to its previous value, discarding the user's input. The **Clear** button is used to revert a value being changed back to the previous value before **Enter** is pressed.

When changing values with the knob, if the focused field is *not* currently being edited, **changes made with the knob take effect immediately**. There is no need to press **Enter** after making changes with the knob. If a field *is* being edited, then the knob acts as a simple up/down adjustment to the edited value, and these changes do not take affect until the **Enter** key is pressed.

There are a few other keys the operator can use during input. The +/- button is used to change the sign of a numerical input, such as 45.0 to -45.0, but does not otherwise affect the value. If the field is a numeric field, the left arrow functions as a backspace key, allowing correction of a mis-typed digits. If the field is a multi-choice field, such as a Yes/No field, the left and right arrows function as previous and next choice, respectively.

#### 2.4.1.4 Soft Key Labels

Soft key labels are labels for the buttons located to the immediate right of the display. Each label either indicates the action that is performed when the corresponding key is pressed (such as changing screens), or the state of a data element in the system (such as laser output OFF/ON). In the first case, pressing the corresponding soft key will cause the action to happen, such as changing to the setup screen when the **Setup** soft key is pressed from a module's main screen. In the second case, pressing the soft key will change the associated state, such as turning a laser output ON. Like the editable

data fields above, certain soft keys are programmed to enter a read-only mode when the unit enters remote mode. Read only soft keys are displayed as an outline rather than a solid block.

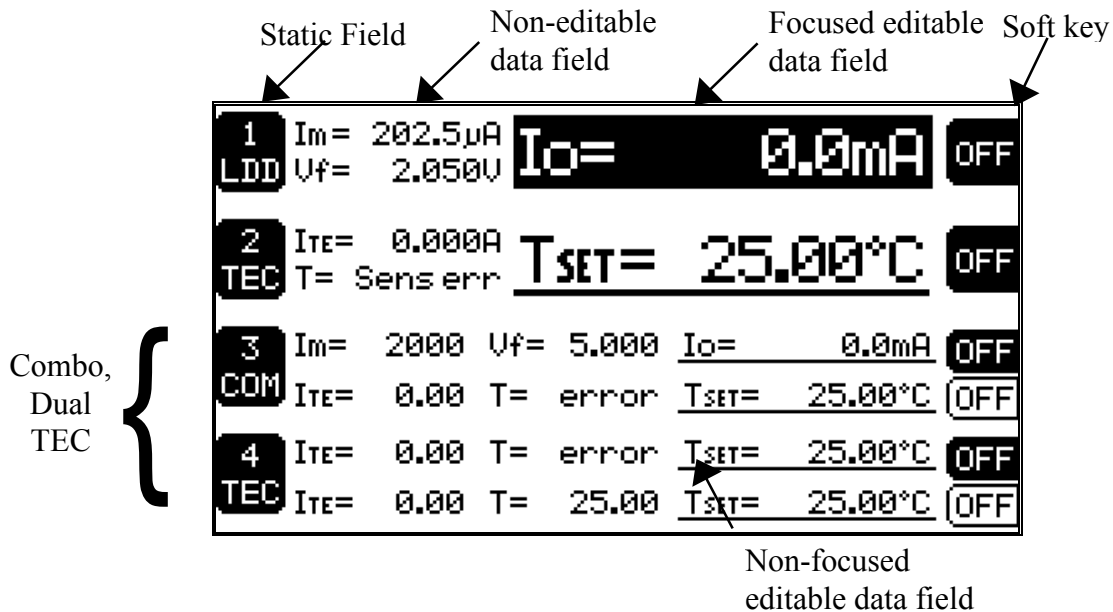

Figure 2 - Various Data Fields Found on the Master Screen

## 2.4.2 Function Keys

The **FUNC** button serves two purposes on the 8000: first, as a quick navigation method that speeds switching between module screens; and second, as a method of setting up and executing user defined macros and special functions.

For macros and special functions, the **FUNC** key is used both to execute and to enter the setup screen on the particular function. For example, if the 8000 supported a special function 1, to enter the setup screen of function 1, press *and hold* the **FUNC** key, then press the **1** key, then release both. This would enter the setup screen for function 1. To execute function 1, press *and release* the **FUNC** key, then press and release the **1** key. If functions are not setup/supported for a particular key, the 8000 will beep.



### 2.4.3 Menu Structure

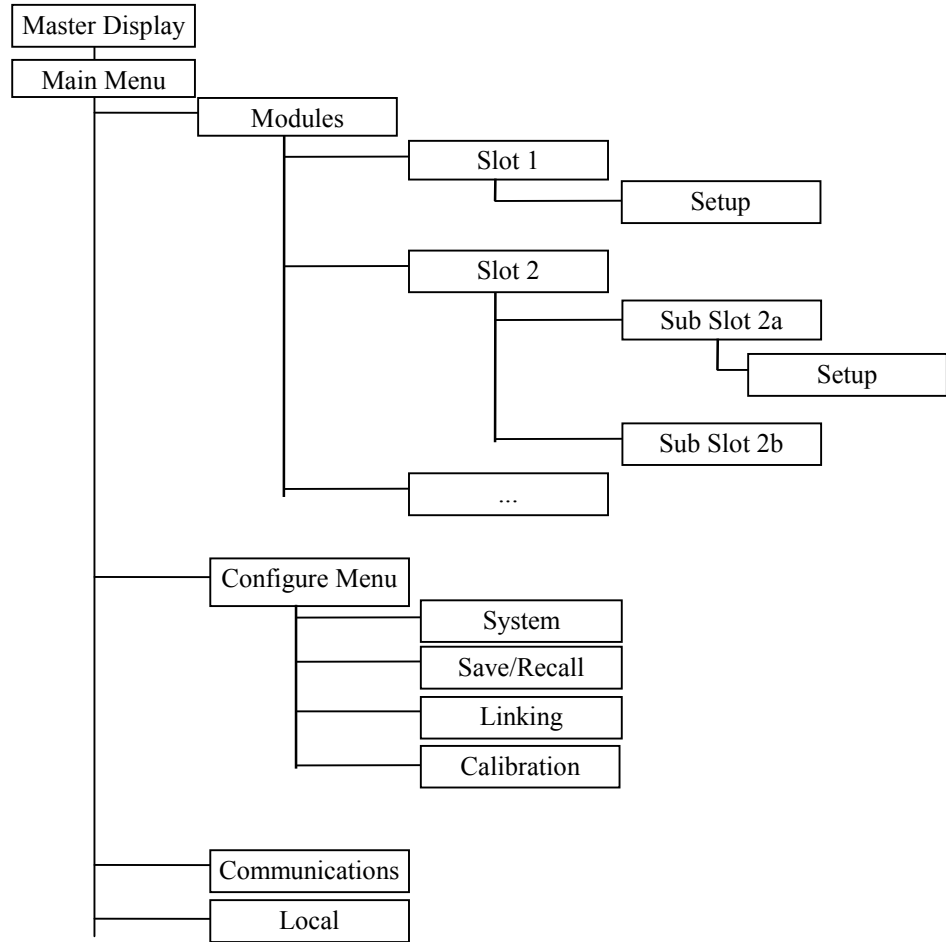

Figure 3 - Model 8000 Menu Structure

## 2.4.4 Master Display

The Master Display is shown in Figure 4 and Figure 5. This is the highest level display and indicates the general status of up to four modules or submodules in the system at a time.

The master display has two modes of operation, **Expanded** and **Condensed**. Figure 4 shows the master display as it would be viewed in **Expanded** mode. Each channel is displayed in one fourth of the display. When the system has modules with multiple submodules, such as the dual TEC or Combo module, each submodule is displayed separately, and the module ID box on the left shows the slot number with an 'a', 'b', etc. after the module number to indicate the submodule. When the total number of modules and submodules exceeds four, pressing the **MASTER** key repeatedly pages down through the list of modules.

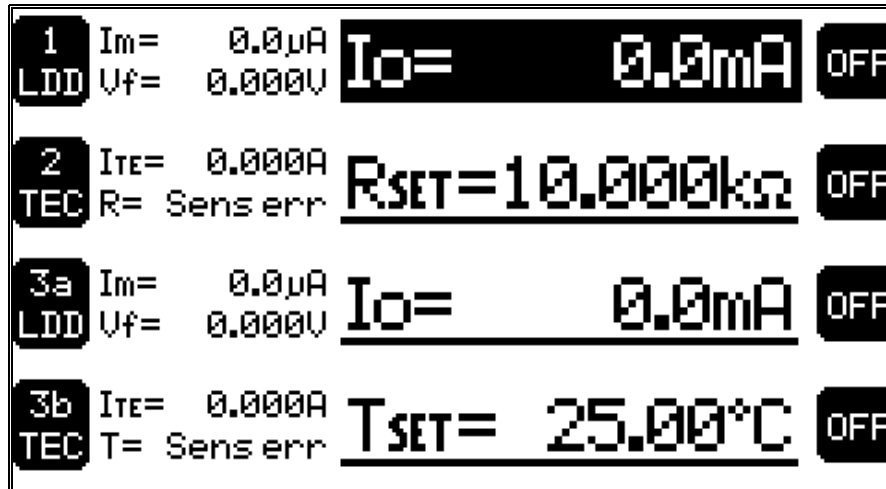

Figure 4 - Master Display, Expanded Display

Figure 5 shows the master display in **Condensed** mode. Instead of displaying a combo or dual module as two separate elements on the master display, they are combined into a single element. Notice that each combo and dual element has two ON/OFF soft keys, one active and the other disabled. In this mode, the **MASTER** button toggles the active ON/OFF button for the combo/dual modules.

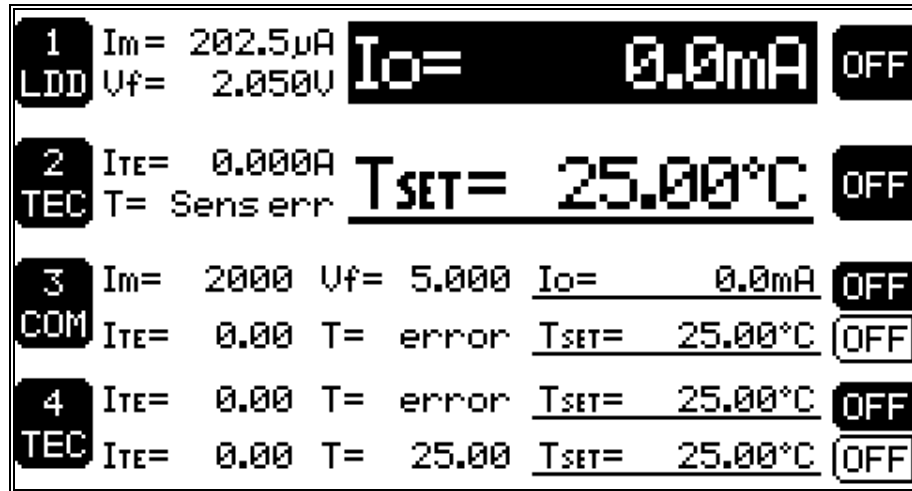

Figure 5 - Master Display, Condensed Mode

The Master Display can be accessed from any screen in the system by pressing **MASTER**. For slots not containing a module, the text “Not installed” is displayed next to the slot number.

## 2.4.5 Main Menu

The Main Menu is shown in Figure 6. This is the second highest menu and is used to access four general system functions:

1. **Modules** - Pressing the adjacent soft key gives access to each of the four "slot" positions for setup and control of each module.
2. **Config** - Pressing the adjacent soft key gives access to the general configuration menu, with soft keys to access system configure, save/recall, and linking screens.
3. **Comm** - Pressing the adjacent soft key gives access to the GPIB and RS232 parameters.
4. **Local** - When the unit is in remote mode, either through GPIB or RS-232C communications, the **Local** soft key will be available. Pressing it returns the 8000 to a local state. When in local mode, this key does *not* appear on the display. The 8000 is placed in remote mode through GPIB or RS232 communication, or during the execution of a macro or special function.

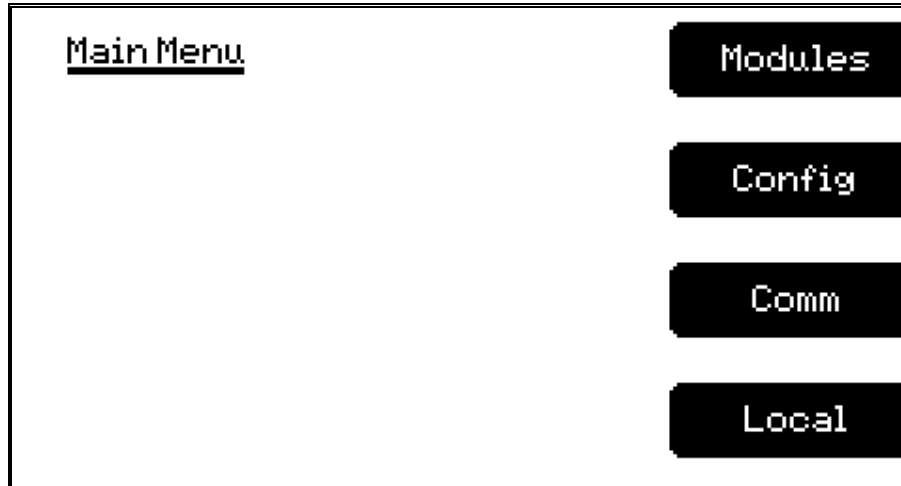

Figure 6 - Main Menu

#### 2.4.6 Configure Menu

The configure menu provides access to the system configuration, save/recall, linking, and calibration screens.

#### 2.4.7 System Configure Screen

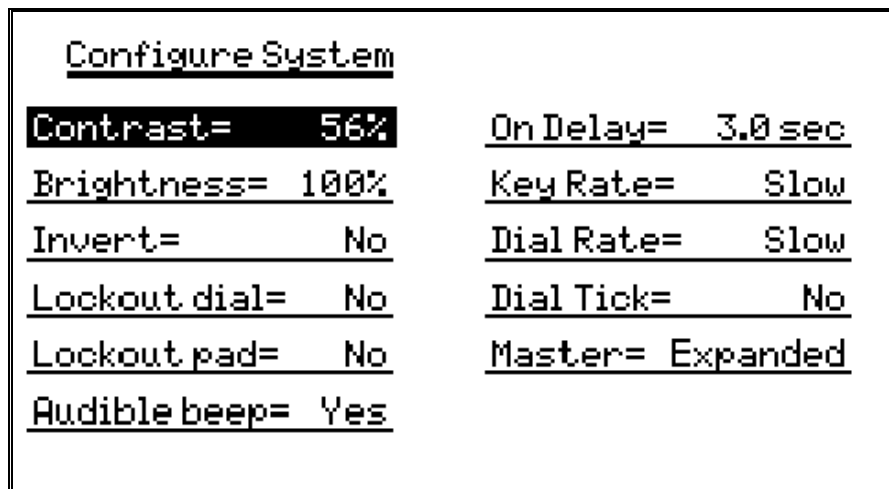

Figure 7 - Configure System Screen

The system configure screen controls basic operation of the 8000 system. Brightness varies the backlighting intensity. Contrast is used to optimize the viewing angle.

**Invert** inverts screen to be white on black rather than black on white.

**Lockout dial** disables the dial to avoid accidental changes in active data fields when the dial is bumped.

**Lockout pad** locks out the data entry portion on the keypad. Navigation keys, such as up and down, **MENU**, and **MASTER** continue to work.

Note that both the Lockout dial and Lockout pad settings are temporarily suspended while in the Configure System Screen, allowing the dial and keypad lockout settings to be changed while in this screen..

**Audible Beep** controls the system's audible beeper. The beeper indicates errors, invalid data entry, and other situations where the 8000 needs to alert the user.

**On Delay** controls the delay time from the moment a Laser Diode Driver is turned on by the user to the actual time the output is energized. The delay time is programmable from 0 seconds to 30 seconds. The default setting is 3 seconds.

**Key Rate** - this controls the speed at which, when a key is held down, it repeats. Settings are **Slow**, **Medium**, and **Fast**.

**Dial Rate** - like the **Key Rate** setting, this controls the acceleration of the dial as it is turned. Settings are **Slow**, **Medium**, and **Fast**.

**Dial Tick** - when set to **Yes**, the dial will produce a tick sound for each increment or decrement of the dial.

**Master** - this controls the format of dual and combo modules on the master display (see section 2.4.4). Settings are **Expanded** and **Condensed**.

## 2.4.8 Save/Recall Screen

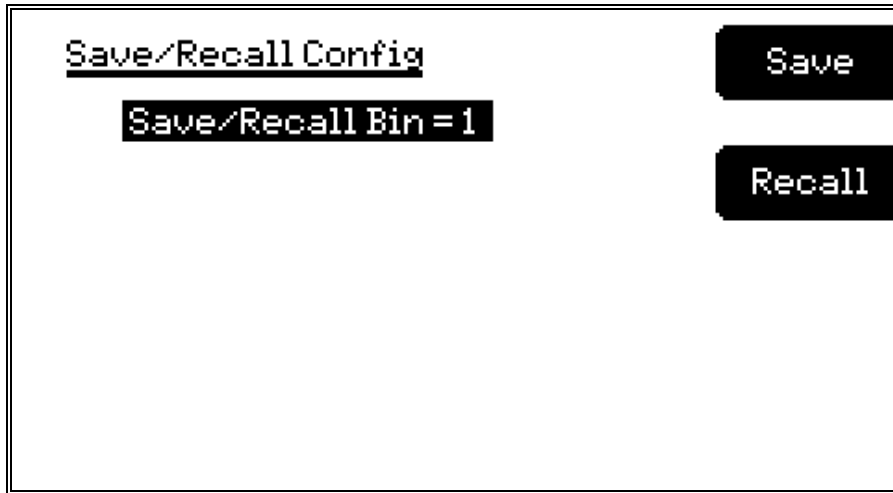

**Figure 8 - Save/Recall Screen**

The Save and Recall functions are used to store and retrieve 8000 setup configurations for future use. For example, a specific test setup may be saved for later use, and then another setup may be used presently. Then, when the user desires to perform the specific test, its setup is simply recalled.

Non-volatile memory is used for saving the instrument parameters. When a save operation is performed, all of the parameters which are currently in effect on the 8000 are stored. The user selects a “bin” number for saving the parameters. Then, when that “bin” number is recalled, the 8000 is restarted and the parameters are reconfigured to the previously stored values.

A special “bin 0” is reserved for the reset state. Recalling bin 0 will reset all modules in the system to factory defaults.

## 2.4.9 Linking Screen

#	Src	Condition	Action	Tgt	
1	<b>1a</b>	<u>Out Tol</u>	<u>Turn Off</u>	<u>1b</u>	
2	<u>None</u>				<b>Clr All</b>
3	<u>None</u>				
4	<u>None</u>				
5	<u>None</u>				
6	<u>None</u>				
7	<u>None</u>				<b>PgDn</b>
8	<u>None</u>				

Figure 9 - Link Screen

The linking screen allows the condition of one module to affect one or more other modules in the system. The **Clr All** soft key allows clearing of all defined links. To clear a single link, simply change the **Src** field to **None**. The system supports up to 32 links.

As an example of linking, consider a system containing a laser and TEC module in slots 1 and 2, respectively. The TEC module cannot operate when the laser is off because condensation will form on the laser and may damage it. However, the TEC must be turned on whenever the laser is on to protect it from overheating. First, program the TEC high and low temperature limits to the operating range of the laser. The following three links will then ensure these conditions are met:

#	<u>Src</u>	<u>Condition</u>	<u>Action</u>	<u>Tgt</u>
1	1	On	Turn On	2
2	1	Off	Turn Off2	
3	2	T Lim	Turn Off1	

Link #1 turns on the TEC whenever the laser is on. Link #2 turns *off* the TEC whenever the laser is off. Link #3 turns off the laser if the TEC exceeds its temperature limits. There is no need to define a fourth link to turn off the TEC on a T Lim condition because if Link #3 turns off the laser, Link #2 will automatically turn off the TEC.

As shown in the example above, it is possible to setup a level of control that would normally only be possible with a computer-based monitoring system.

See each module's manual for a list of link conditions.

When the unit enters remote mode, the linking screen is not accessible.

#### 2.4.10 Calibration Screen

See calibration chapter for detailed information.

#### 2.4.11 Configure Communications Screen

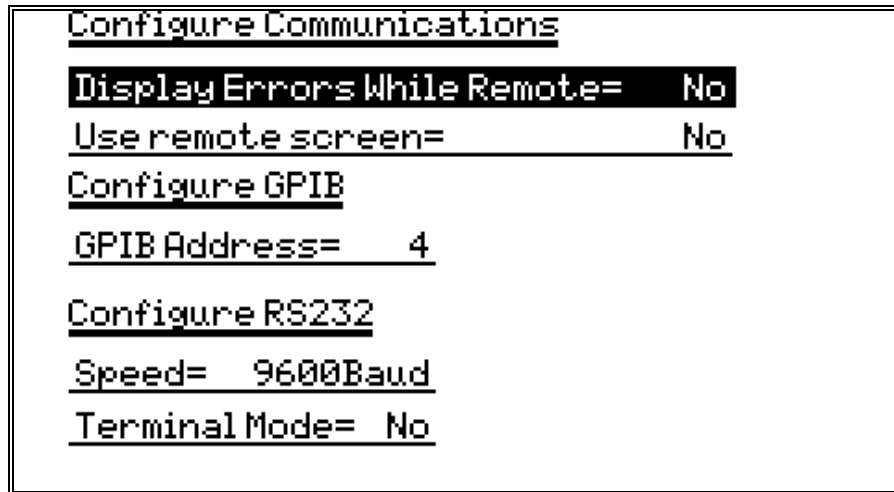

Figure 10 - Configure Communications Screen

**Display Errors While Remote** controls the announcement of errors on the 8000's screen. When this setting is set to **Yes**, then all errors will pop up on the 8000 screen, even in remote mode. When the setting is **No**, error's are not displayed on the 8000 screen while in remote mode (but will be displayed in local mode). This *does not* affect the error list which is queried via the GPIB **ERR?** query. It is intended to keep the 8000 screen free of error messages while operating in remote mode.

**Use remote screen** is intended to help improve throughput on fully loaded 8000 systems. Although throughput improvement is not significant, it may reduce slightly the latency time between the sending of a GPIB command and the actual time the command is processed. When this setting is **Yes**, the 8000 will switch to a "remote" screen when entering remote mode, although the **MENU** and **MASTER** buttons can be used to switch out of this screen. When leaving remote mode, the 8000 will switch to the master display, unless the user has left the remote screen.

The **GPIB Address** is the IEEE-488 device address assigned to the 8000. Valid addresses are 1 to 31.

**Terminal Mode** enhances the interface with the 8000 when communicating via the RS232 in a ANSI/VT100 compatible serial terminal.



**Speed** sets the baud rate of the RS232 serial port.

See the *Computer Interfacing Manual* for additional information on **Terminal Mode** and **Speed**.

### 2.4.11.1 Error Message Control

Error messages may appear on the display when error conditions occur which force the output off or reflect hardware errors in the 8000. Chapter 8 contains an explanation of the error message which may be reported by the 8000. Display of error messages on the 8000 screen may be disabled while in remote mode by setting **Display Errors While Remote** to **No**. Errors will continue to accumulate in the error queue, but will not be displayed on-screen.

## 2.5 Rear Panel Familiarization

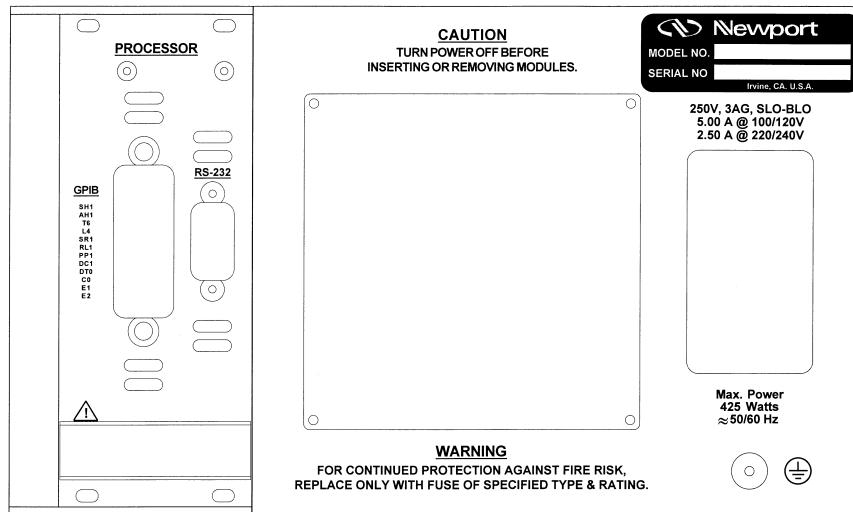

Figure 11 - Rear Panel

### 2.5.1 GPIB Connector

The GPIB connector, located on the back of the microprocessor module, allows full remote control as described in the *Computer Interfacing Manual*. The connector accepts a standard IEEE-488 cable for remote control, and uses Metric lock screws.

### 2.5.2 RS-232 Connector

The 8000 has one RS-232 connector located on the back of the microprocessor module for remote control via the serial port. See section the *Computer Interfacing Manual* for a more complete description of the RS-232 interface.

### 2.5.3 Input Power Connector

Accepts a standard line cord for AC input. Also selects one of four AC input settings: 100V, 120V, 220V, and 240V. The cord must be removed to change the setting. A small screwdriver will open the top of the module and expose the rotary switch. Select the range that is closest to your expected nominal RMS line voltage. The voltage selection is set for 120 VAC prior to shipping. A caution sticker is then placed over the input power connector to help insure the customer checks for proper voltage.

#### CAUTION

Do not exceed 250 VAC on the line input.

Do not operate with a line voltage that is not within  $\pm 10\%$  of the line setting. Too low of an input voltage may cause excessive ripple on the DC supplies. Too high of an input voltage will cause excessive heating.

### 2.5.4 GND Post

Provides access to chassis ground, which is also an earth ground as long as a standard 3-wire line cord is used. This is a protective conductor terminal to be used to achieve chassis grounding requirements when the main connectors don't provide an earth ground terminal. Use a minimum of 18 gauge wire to connect to this terminal.

## 2.6 Power Supplies ---

AC power is supplied through the rear panel input power connector which provides in-line transient protection and RF filtering. The input power connector contains the fuses and the switch to select series or parallel connection of the transformer primaries for operation at 100 VAC, 120 VAC, 220 VAC, or 240 VAC.

### 2.6.1 Module Power Supplies

There are separate module power supplies for each "slot" which contains either a laser driver and/or a TEC controller. These linear supplies provide analog and digital circuit power to each module as well as laser/TEC drive and photodiode bias.

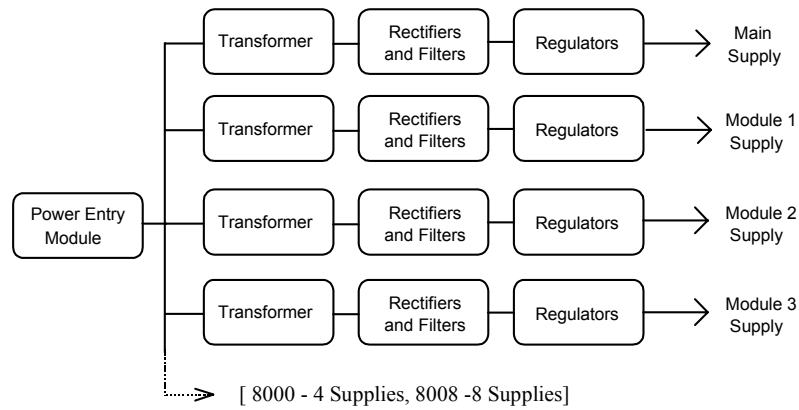

Figure 12 - Power Supply Block Diagram

### 2.6.2 Main Supply

This OEM linear supply provides digital circuit power for all functions except the module slots. It also provides fan power and RS232 drive.

### 2.7 Warm Up and Environmental Consideration

Operate the 8000 at an ambient temperature in the range of 0 to +40°C. Storage temperatures should be in the range of -20 to +60°C. To achieve rated accuracy, let the 8000 warm up for 1 hour. For greatest accuracy, recalibrate when ambient temperature changes more than a few degrees.

#### CAUTION

Operating above +40°C can cause excessive heating and possible component failures.



## 3. Laser Diode Driver Module Operation

### 3.1 Laser Diode Driver Module

---

#### 3.1.1 Introduction

The 8500 and 8600 Series laser modules are precision current source modules for use in the 8000 Modular Controller. It may be installed in any of the bays at the rear of the 8000 and may be interchanged with any other module.

Features of the 8500 and 8600 Series include:

- Service-free modularity (calibration information is stored on the module)
- Closed-case calibration
- High-stability, low noise design
- Flexible setup with 8000 Save/Recall front panel functions
- Photodiode feedback control mode
- Modulation input (8500 Series only)
- Fault detection
- Current and voltage limiting
- Special Configuration for MOPA Lasers (65xxM modules)

#### 3.1.2 Installation

This section describes the procedures for installing and removing a module from the 8000.

#### NOTE

The save/recall bin information will be lost upon detecting any change in the module configuration (such as installing a new module).

#### CAUTION

Although ESD (electrostatic discharge) protection is designed into the module, operation in a static-free work area is recommended.

#### CAUTION

Do not plug-in or unplug a module with the AC power on.

To install the module into the 8000, follow these steps:

1. **Turn the 8000 power off.** Installing a module with the 8000 on can damage the module and the 8000.
2. Place the module into an open bay on the back of the 8000 and slide the module into place. There are tracks at the top and bottom of the bay which guide the module into place. Screw the module locking screws into the back panel to secure the module.

To remove the module from the 8000, follow these steps:

1. **Turn the 8000 power off.** Removing a module with the 8000 on can damage the module and the 8000.
2. Unfasten the module locking screws which secure the module to the 8000 back panel.
3. Grasp the module by the handle which extends from the bottom of the back panel. Gently, but firmly, pull the module out.

### 3.1.3 Laser Diode Protection Requirements

Laser diodes are extremely sensitive to electrostatic discharge and current spikes (transients). Damage can result in reduced output power, shift in threshold current, changes in beam divergence, and ultimately failure to lase (LED-like output only).

Newport precision current sources and controllers offer the most advanced laser protection features available, including power line filters, clamping current limits, and slow-start-up circuits.

However, no instrument can protect against all conditions, especially ESD at the laser. In order to optimize immunity from radiated or conducted electromagnetic energy, e.g. static discharge, the following guidelines for the laser diode must be adhered to:

- ◆ ESD is the primary cause of premature laser failure. As a minimum, use anti-static wrist straps (grounded with 1 M $\Omega$  resistor), anti-static floor coverings, grounded soldering irons, and grounded work areas. Ionized air blowers are also recommended.
- ◆ Laser diode leads should be shorted whenever the laser is transported or stored.
- ◆ Select a driver module with the lowest possible current rating that still exceeds the laser's maximum operating current. For example, a laser with a maximum operating current of 150 mA should be driven by the 6505 500mA laser driver module.

- ◆ Recess the laser diode inside a metal shielded enclosure, such as a Model 700C laser diode mount, recessed at least ¼” with the minimum aperture necessary to allow beam exit (less than 0.125”).
- ◆ If industrial loads are switched in or near your laboratory, use isolation transformers and/or surge suppresser power strip with your laser current source.
- ◆ Isolate your laser current driver with a surge suppresser when using a common line with laboratory power supplies, soldering irons, or other electronic instruments. Avoid using such devices on the same surge suppresser as your laser source.
- ◆ Make sure the all cables to the laser diode are securely fastened. Avoid “bundling” current source cables with other cables in your laboratory,
- ◆ Set current and voltage limits to appropriate levels, following the laser manufacturer’s recommendations (or to just above the expected operating current). Suggestions include setting the compliance voltage no more than 10% above  $V_F$ , and setting the current limit at or below the maximum operating current of the laser diode.
- ◆ Avoid ground loops. Don’t ground the LDD cable shield to the laser diode body.

Added protection from electrostatic discharge (ESD) can be obtained by inserting ferrite beads and capacitors near the laser diode as shown below.

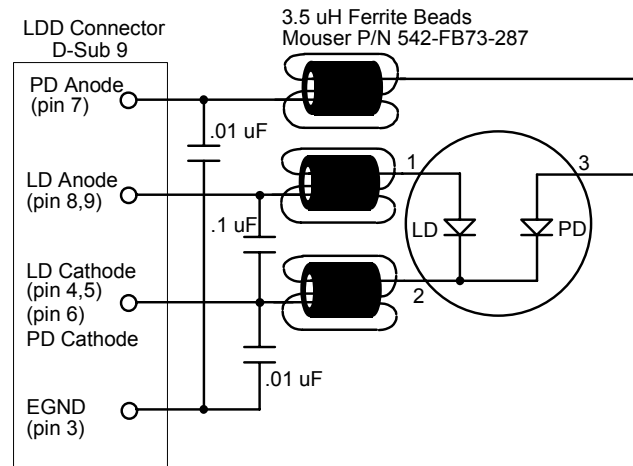

**Figure 13 - Laser Diode Protection Circuit**

Notes:

1. When applying high speed modulation to the laser diode, this circuit may reduce the maximum modulation frequency.
2. The temperature controlled mount is earth grounded through pins 5 and 6 of the TEC D-sub connector.

3. On all 700 series mounts, the temperature control cable must be connected for maximum protection.
4. For maximum laser diode protection, the diode should be recessed, as in the 700-C mount.

## 3.2 Laser Safety Features

---

### 3.2.1 Conditions Which Can Automatically Shut Off the Laser Output.

- Laser Open Circuit<sup>1</sup>
- Laser Compliance Voltage Limit<sup>1</sup>
- Laser Hard Current Limit<sup>1</sup>
- Laser Interlock State Changed<sup>1</sup>
- Laser Photodiode High Current Limit
- Laser Photodiode High Power Limit
- Laser Intermittent Contact (if enabled, default disabled)
- A Linked Function

With the exception of the linked functions, some of these conditions can be disabled by clearing the appropriate bits in the Laser OUTOFF register. See the *Computer Interfacing Manual*.

### 3.2.2 Key switch Interlock

The LASER ENABLE key switch on the front panel will shutoff, or not allow to be turned on, any laser outputs while in the OFF position, per CDRH requirements.

### 3.2.3 Turn On Delay

The 8000 is CDRH Compliant with a user programmable turn on delay. The default turn on delay is three seconds, but is user programmable from 0 to 30 seconds. The delay setting is in the system configure screen, which can be reached by pressing the **MENU** button, followed by the **Config** soft key, then the **System** soft key. The field is labeled **On Delay**.

## 3.3 The Laser Connectors

---

On all laser modules, except the MOPA, a 9-pin female D-connector is used for input and output connections, as shown by the pin-out diagram below.

Pin	Description
-----	-------------

---

<sup>1</sup> This condition will always shutdown the laser output, and cannot be disabled.



1,2	Interlock
3	Chassis Ground
4,5	Laser Cathode
6	Photodiode Cathode (+)
7	Photodiode Anode (-)
8,9	Laser Anode

**Table 1 - Laser Connector Pinouts**

For MOPA modules, a 15-pin male D-connector is used for the MOPA cable and a 9-pin male connector is used for the TEC jumper cable, as shown below.

MOPA Connector		TEC Strap Connector	
Pin	Description	Pin	Description
1	TE-	1,2	TE+
2	Analog Ground	5	Ground
3	OSC-/LAS-	6,7	TE-
4	OSC+	8	Therm+
5	+12V Fan	9	Therm-
6	LAS+		
7	N/C		
8	TE+		
9	Interlock+		
10	Therm-		
11	Therm+		
12	MPD+		
13	MDP-		
14	LED+		
15	LED-		

**Table 2 - MOPA Laser Connector Pinouts**

### 3.3.1 Modulation

#### CAUTION

Do not connect or disconnect a signal to the modulation input with the laser on.

A BNC connector is provided for an external modulation signal. See section 3.5.3.2 for a description of modulation bandwidth.

Each 100 mV change in the modulation input is equal to 1% of the maximum drive current of the module. For example, 100 mV input on a 6560 module (6 A driver) would equate to 60 mA of drive current. However, regardless of the input voltage, the current cannot exceed the current limit.

### 3.3.2 Photodiode Bias Control

An adjustment is provided for 0V to 5V reverse bias adjust on single channel modules. Dual, Combo, and MOPA modules do not have a photodiode bias control and have fixed bias at either 0V or -5V.

### 3.3.3 Photodiode

A BNC connector is provided for photodiode connections. It is the same input as pins 6 and 7 in the 9-pin D connector with the anode on the shell. MOPA and combo modules do not have this BNC connector.

**CAUTION**

Do not disconnect the photodiode with the laser on.

### 3.3.4 Interlock

Except on MOPA modules, the interlock pins, 1 and 2, must be connected together to complete the circuit and allow the laser operation. Pin 1 is connected to a +5V supply through a 10 k $\Omega$  resistor, and pin 2 is connected to ground through a 1 k $\Omega$  resistor. On MOPA modules, the interlock pin 9 is connected to pin 2.

## 3.4 Connecting to Your Laser

---

When connecting laser diodes and other sensitive devices to the module, we recommend that the 8000 be powered-up and the laser output be off. In this condition, a low impedance shunt is active across the output terminals. When disconnecting devices, it is only necessary to turn the laser output off.

Except for MOPA modules, pins 4 and 5 of the 9-pin D-connector are the negative output, and pins 8 and 9 are the positive output current connections. These pins are jumpered to provide greater contact area for the output connection.

**NOTE**

Whenever external connections are made to the output at pins 4 and 5, and 8 and 9, these connector leads should be jumpered to ensure the greatest laser diode safety.

We also recommend the use of the 9-pin D-connector for your interface rather than binding posts, or loose wires. This will insure the best connection.

### 3.4.1 Laser Diode Connections and Shielding

#### CAUTION

Before connecting the laser diode to the module, be sure that the LASER ENABLE is in the OFF position. Before turning on the laser output, be sure that the current limit and voltage compliance limit have been correctly set.

#### NOTE

The cable connections to the laser must be secure to avoid an open circuit, should they be jostled or bumped. Should an open circuit occur during laser operations, the laser output will normally be turned off automatically.

Except for MOPA modules, special circuits in the laser module are present for detecting intermittent contacts and connections. These circuits detect the abrupt change in current that occurs when the output circuit is opened.

Experience indicates that should an open circuit occur during laser operation, the laser may be damaged. Therefore, secure cabling is important.

#### NOTE

Although the Intermittent Contact circuitry works well in helping to protect the laser diode, there is still a danger in having poor connections, as no circuit can protect completely.

#### NOTE

It is possible with some modes of modulation, especially square-wave, to trigger the intermittent contact circuit and cause a shut-down. If this is the case for you, the intermittent contact feature may be disabled in the laser set up menu, with reduced laser protection in the case of poor connections.

It is recommended that the connections to the module output be made using twisted wire pairs with an earth-grounded shield available at pin 3, except MOPA modules, that use the ground post on the mainframe. The output terminals of the module are

left floating relative to earth ground to suppress AC power-on/power-off transients that may occur through an earth-ground path. If the output circuit is earth-grounded at some point (such as through the laser package and mount), the user must be careful to avoid multiple earth grounds in the circuit. Multiple earth grounds may provide circuit paths that shut-out the driver and may damage the laser.

### 3.4.2 Photodiode Feedback Connections

The photodiode signal is input at the 9-pin D-connector at pins 6 and 7, or the photodiode BNC.

Many laser diode modules contain an internal photodiode that monitors the back-facet emission of the laser. Usually, one side of the photodiode is internally connected to either the laser anode or cathode. Figure 14 through Figure 17 show the recommended connections and shielding for the various configurations of laser diode modules and photodiode feedback schemes. The photodiode circuit is isolated from ground and the laser circuit. Therefore, when using a 4-pin package with no common connections, place a  $1\text{M}\Omega$  resistor between the laser diode cathode and the photodiode anode to provide a bias return for the photodiode circuit.

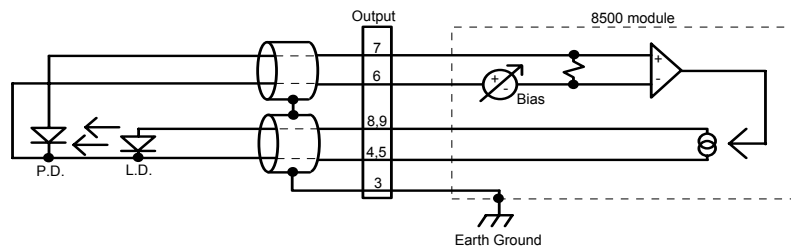

Figure 14 - Common Laser Cathode / Photodiode Cathode

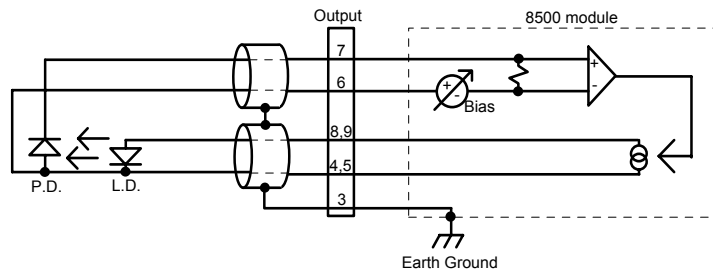

Figure 15 - Common Laser Cathode / Photodiode Anode

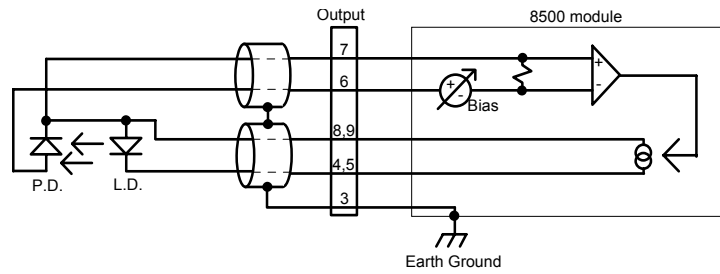

Figure 16 - Common Laser Anode / Photodiode Cathode

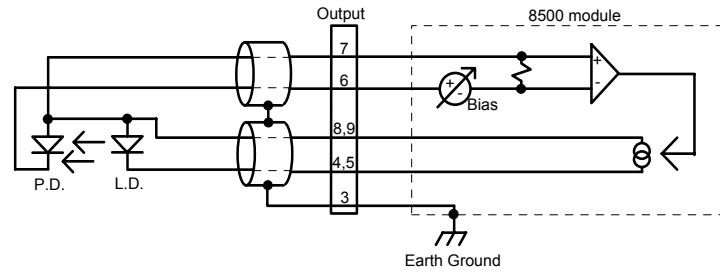

Figure 17 - Common Laser Anode / Photodiode Anode

### 3.4.3 Sync Out - Option

The Sync Out connector on the back of the 8600 series is a custom option, normally the connector will not be loaded.

### 3.4.4 Grounding Consideration

The laser outputs of the module are isolated from chassis ground allowing either output terminal to be grounded at the user's option.

## 3.5 Laser Module Operation

### 3.5.1 Quick Start

After the power-on sequence is complete, the 8000 goes to the Master display. To set up a laser module, press the **MENU** button, then the **Modules** soft key, then select the slot that the module resides in, and finally, the **Setup** soft key. At this point, the display shows all laser parameters. Using the cursor keys, the numerical keypad, knob and **ENTER**, select the desired functions and set the parameter values. When finished, return to laser display with **Prev** (previous) soft key.

Enter the desired set point value using the numerical key pad and **ENTER**, or use the knob. Press the **OFF** soft key to operate the laser. The **OFF** changes to **ON**. To turn the laser off, press the **ON** soft key.

### 3.5.2 Laser Main Screen

The laser main screen is shown in Figure 18 and described in detail below. Certain features are not available on some modules.

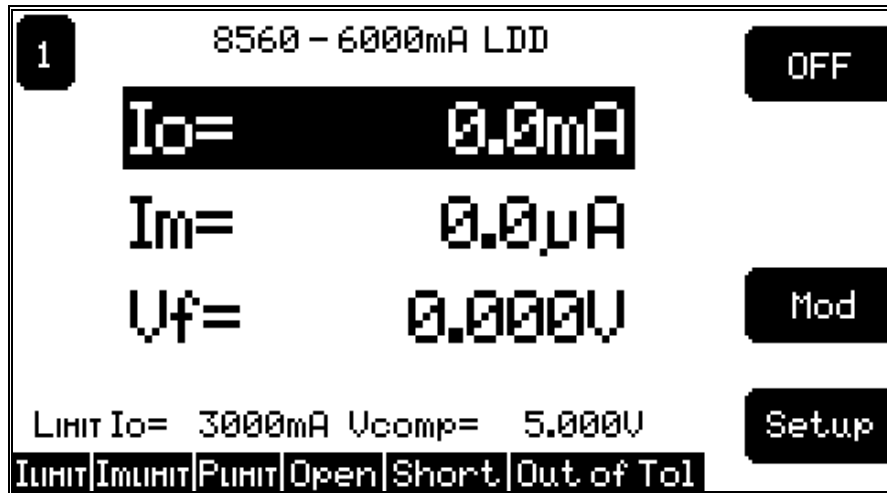

Figure 18 - Laser Main Screen

**Io=**, **Im=** or **Po=** - When these fields are editable, such as the **Io=** field in the figure above, they indicate the corresponding set point. Non-editable fields, such as the **Im=** and **Vf=** fields above, indicate measured values, such as laser current or voltage, photodiode current, or photodiode power.

**OFF/ON** - Indicates the state of the laser's output. Pushing the adjacent soft key toggles the state.

**Mod** - This button will be available only on 8000-22 combo modules while in **Io** mode. Pushing the adjacent soft key activates the modulation setup screen.

**Setup** - Pushing the adjacent soft key activates the setup screen.

The bottom line on the display has 6 “LED” elements, each indicating a particular state of the laser. They are defined as:

<b>ILIMIT</b>	When illuminated, indicates the unit is current limiting.
<b>ImLIMIT</b>	When illuminated, indicates the unit has exceeded the monitor photodiode current limit.
<b>PLIMIT</b>	When illuminated, indicates the unit has exceeded the monitor photodiode power limit.
<b>Open</b>	When illuminated, indicates the system has detected an open circuit. Only detected when the unit is on.

<b>Short</b>	When illuminated, indicates the system has detected a short circuit. Only detected when the unit is on.
<b>Out of Tol</b>	When illuminated, indicates the unit is out of tolerance as defined by the <b>Tol Time</b> and <b>Tol Iop</b> settings in the Laser Setup Screen.

### 3.5.3 Laser Setup Screen

The laser setup screen is shown in Figure 19 and described in detail below. Certain features are not available on some modules.

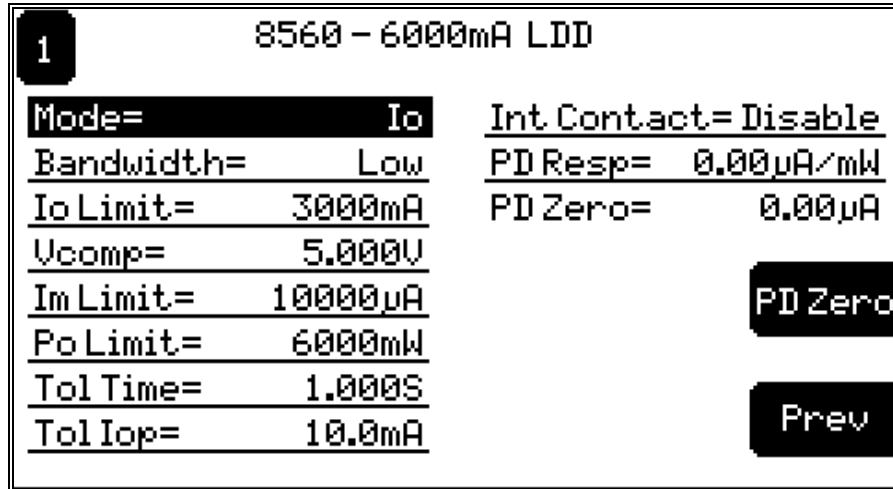

Figure 19 - Laser Setup Screen

#### 3.5.3.1 Mode

The **Mode** setting controls how the laser driver current is controlled. There are three modes: **Io**, **Im**, and **Po**.

In the **Io** mode, the active set point is the actual drive current. A set point of 1000 mA will cause the module to drive 1000 mA through the laser diode, assuming the **Io Lim** is set at or above 1000 mA.

In **Im** mode, the set point is the desired amount of photodiode current, in µA. Unlike the **Io** mode, **Im** mode will drive whatever current is necessary through the laser diode, up to the limit, to achieve the set point photodiode current.

**Po** mode is simply an extension on the **Im** mode, allowing the user to operate the system in milliwatts of power. The photodiode power set point, in mW, is converted to photodiode current using the **PD Resp** value from the setup screen.

#### 3.5.3.2 Bandwidth

This setting is used to control noise and laser current modulation rates. Allowable settings are **Low**, **Low CW**, and **High**. **Low CW** allows a maximum modulation rate of 30 Hz, and operates with the least noise. **Low** allows up to 10 kHz modulation, while **High** allows full bandwidth modulation. Modulation is disabled in **Im** and **Po** modes. The MOPA module does not have this setting.

### 3.5.3.3 **Modulate (MOPA Modules Only)**

This setting is used to select which laser driver is modulated by the external modulation input. The choices are **Osc** for the oscillator driver, or **Amp** for the amplifier driver.

### 3.5.3.4 **Io Lim**

As one of the safety features of the Laser modules, the **Io Lim** sets a maximum allowable current drive for the laser diode. The system will also limit current set points to this value when operating in the **Io** mode. Two conditions can be generated when the driver reaches this limit. The lesser of the two is the soft current limit. The soft limit, indicated by **ILIMIT** on the status line of the Laser Main Screen, indicates that the laser module is limiting the current drive to the laser diode, but otherwise operating as normal. The second condition is a hard limit, which indicates that the current drive attempted to exceed the current limit faster than the circuitry could limit it. This condition causes the laser module's output to be shutdown. Both of these conditions are monitored in circuitry on the module itself, and in the case of the hard limit, shutdown is within microseconds of the condition being detected.

### 3.5.3.5 **Vcomp**

The voltage compliance setting controls the shutdown of the laser module output when the forward voltage of the laser exceeds the compliance setting. Like the current limit described above, the voltage compliance is monitored in circuitry on the module itself, allowing for shutdown within microseconds of the condition.

### 3.5.3.6 **Im Lim**

The photodiode current limit is a software monitored limit on the current delivered from the photodiode. Because this limit is a software monitored limit, shutdown can occur up to a second after the condition is true.

### 3.5.3.7 **Po Lim**

Like the **Im Lim**, the photodiode power limit is a software monitored limit on the power delivered from the photodiode. For this limit to function, the user must set a **PD Resp** value other than zero. Because this limit is a software monitored limit, shutdown can occur up to a second after the condition is true.

### 3.5.3.8 **Tol Time and Tol Iop**

The **Tol Time** and **Tol Iop** elements are used for determining when the laser is “in tolerance.” The **Tol Time** value is expressed in seconds, and can range from 0.001



seconds to 50 seconds. The **Tol Iop** value is displayed in mA, and can range from 0.1 mA to 100 mA. When operating in **Im** or **Po** modes, The **Tol Iop** setting is ignored, and fixed values of 50  $\mu$ A and 50 mW, respectively, are used. The laser is considered in tolerance after it has been within the tolerance setting for the set number of seconds. If at any time it goes outside the tolerance range, the time restarts at zero.

As an example, if the **Tol Time** is set to 5 seconds, the **Tol Iop** is set to 2 mA, and the current set point was 1000 mA, the laser module would have to stay within 998 mA and 1002 mA to be within tolerance. Out of tolerance is indicated by a **Out Of Tol** status field on the bottom of the Laser Main Screen.

### 3.5.3.9 Intermittent Contact (Int Control)

The **Int Control** setting controls the detection of intermittent contacts caused by faults cables or connectors. An intermittent contact, if enabled, will shutdown the laser with an “open” error. The system allows the user to disable the circuit when working in an electrically noisy environment that might cause a false detection. The circuit is automatically disabled in the High Bandwidth Mode.

### 3.5.3.10 PD Resp

The **PD Resp** element is the conversion factor between photodiode current and photodiode power, and is expressed in  $\mu$ A per mW. If this value is zero, the system will not operate in **Po** mode.

### 3.5.3.11 PD Zero

The **PD Zero** element is the photodiode offset that is removed from the photodiode read back before any values are displayed, and conversely, is added to any photodiode set point. The photodiode offset is a combination of any dark current or stray light picked up while the laser is off. Pressing the **PD Zero** soft key sets this element to the photodiode current that is present on the photodiode input. To clear it, simply press the **PD Zero** soft key a second time.

### 3.5.3.12 Prev soft key

Pushing the **Prev** soft key returns to the previous screen.

## 3.5.4 Laser Modulation Setup Screen

Newer combo modules (8000-22) have onboard modulation circuits. The modulation setup screen has six variables, **Mod Enable**, **Mod Frequency**, **Mod Amplitude**, **Mod Type**, **Io min**, and **Io max**. **Mod Amplitude**, **Io min**, and **Io max** are interrelated, see below.

### 3.5.4.1 Mod Enable

**Mod Enable** turns the modulation circuit on or off.

### 3.5.4.2 Mod Frequency

The modulation circuit is capable of a frequency between 200 Hz to 300 kHz. Below 2 kHz, the frequency is displayed in Hz, while above 2 kHz, the frequency is displayed in kHz.

### 3.5.4.3 Mod Amplitude

Modulation amplitude is entered in milliamps. The amplitude is the positive and negative amplitude of the sine or square wave around the  $I_o$  set point. The actual **Mod Amplitude** set point has a resolution of 1% of the full scale output. When changing **Mod Amplitude**,  **$I_o$  min** and  **$I_o$  max** are recalculated using the  $I_o$  set point and the new modulation amplitude to derive  **$I_o$  min** and  **$I_o$  max**. For example, if the set point was 50 mA and the amplitude was 15 mA,  **$I_o$  min** would be recalculated at 35 and  **$I_o$  max** would be recalculated at 65. Changing  **$I_o$  min** or  **$I_o$  max** has a similar effect on **Mod Amplitude** and the  $I_o$  set point, but in reverse. See section 3.5.4.5 below.

### 3.5.4.4 Mod Type

**Mod Type** selects the type of waveform generated by the modulation circuit: square wave or sine wave.

### 3.5.4.5 $I_o$ min and $I_o$ max

**$I_o$  min** and  **$I_o$  max** can be used in place of the  $I_o$  set point and **Mod Amplitude** to set the top and bottom  $I_o$  levels for the modulation output. Because these values are calculated based on the  $I_o$  set point and **Mod Amplitude** and not stored, they are displayed as a “Modulation Calculator”. Changing either of these values will change the set point and amplitude settings accordingly.

## 3.5.5 Link Conditions

The Laser module supports the following link conditions:

<i>Condition</i>	<i>Description</i>
<b>On</b>	Laser output is on
<b>Off</b>	Laser output is off
<b>Out Tol</b>	Laser is out of tolerance
<b>In Tol</b>	Laser is in tolerance
<b><math>I_o</math> Lim</b>	Laser is current limiting
<b><math>V_f</math> Lim</b>	Laser has reached its voltage limit
<b><math>I_m</math> Lim</b>	Laser has exceeded photodiode current limit
<b><math>P_o</math> Lim</b>	Laser has exceeded photodiode power limit
<b>Interlock</b>	Laser interlock is not closed
<b>Open</b>	Laser module is open circuit
<b>Short</b>	Laser module is shorted

**Table 3 - Laser Link Conditions**

See the section 2.4.9 for a complete description of the linking process.

## 3.6 Laser Module Theory of Operation

Figure 20 shows the functionality of the Laser Module. The following sections detail the theory of operation for each of the blocks in Figure 20.

The circuit block diagrams for each laser mode of operation are shown in Figure 21, Figure 22, and Figure 23. The theory of operation for each mode of operation is discussed in Sections 3.6.9 - 3.6.11.

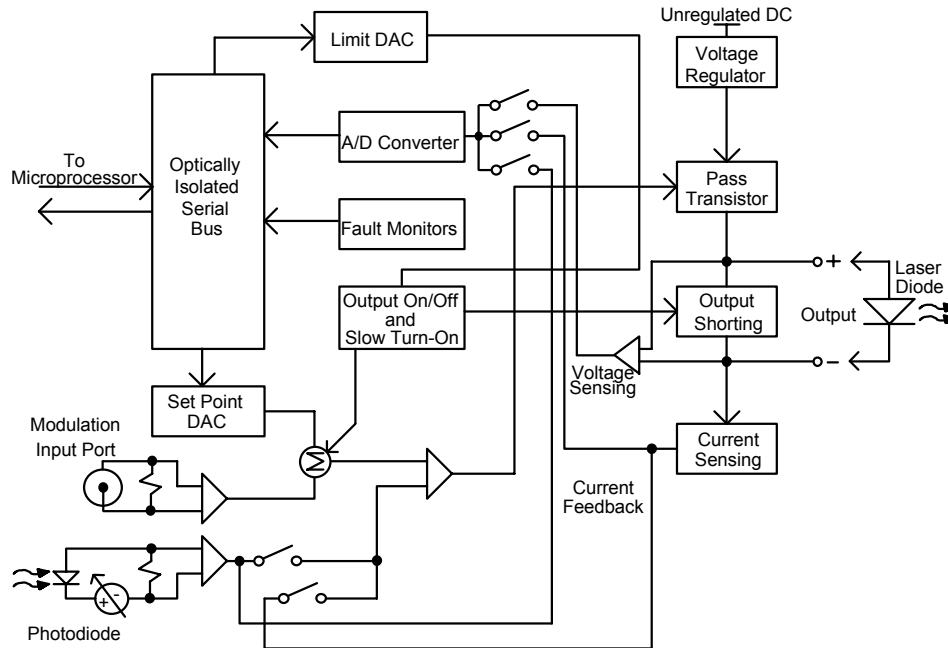

Figure 20 - Laser Module Block Diagram

### 3.6.1 Laser Interface

The laser interface provides optically isolated serial communications between the laser board and the microprocessor. Control signals are passed to the laser board to set the laser board status, current limit, current set points, and photodiode feedback functions. Instructions and data are sent over the serial interface to the optical barrier. Status and data are serially passed back to the microprocessor.

### 3.6.2 Limit DAC

The microprocessor loads the current limit value into the 12-bit DAC. The Limit DAC converts a digital limit signal from the microprocessor to a voltage which

becomes the Limit Set Point voltage for the Output Stage. The current limit value is updated at power-up, at a "bin" recall, and whenever a LIM I value is changed.

### **3.6.3 Set Point DAC**

The microprocessor loads the current set point value into the 16-bit DAC. The Set Point DAC converts a set point value from the microprocessor to a voltage which becomes the current or  $I_{PD}$  set point input to the laser output stage. The laser current set point value is updated at power-up, at a "bin" recall, and whenever a laser set point value is changed.

### **3.6.4 A/D Converter**

The 16-bit A/D converter measures the limit current, actual current, and photodiode current.

### **3.6.5 Current Source Voltage**

The current source voltage is formed by taking the unregulated DC voltage from the power supply and passing it through a regulator and the associated circuitry.

### **3.6.6 Output Shorting**

A relay shorts the LD ANODE and LD CATHODE terminals whenever the laser output is turned off. At the same time a FET is switched on to shunt any current which may appear at the output. When the laser output is turned on, the shunt circuit and short are removed gradually, and in two stages. This ensures transient protection of the laser output.

### **3.6.7 Modulation/Voltage Control Input Port**

The rear panel MOD input connector drives a precision wide-band instrumentation amplifier allowing the differential control signal applied to this port to use a different ground than the laser output terminals. However, due to the input common-mode voltage restrictions the MOD input should be within  $\pm 10$  volts of the laser output terminals.

Each 100 mV change in the modulation input is equal to 1% of the maximum drive current of the module. For example, 100 mV input on a 6560 module (6 A driver) would equate to 60 mA of drive current. However, regardless of the input voltage, the current cannot exceed the current limit.

### **3.6.8 Photodiode Feedback Amplifier**

Photodiode feedback is amplified by a precision instrumentation amplifier. When constant Power mode is selected, the photodiode feedback signal is used to control the laser output.

### 3.6.9 Constant Current, High Bandwidth Mode

This mode of laser operation is shown in Figure 21. In this mode, current feedback is used to control the laser output. The bandwidth is between 50 kHz and 500 kHz, depending on the model.

### 3.6.10 Constant Current, Low Bandwidth Mode

This mode of laser operation is shown in Figure 22. In this mode, current feedback is used to control the laser output.

In this mode, capacitors are switched into the circuit. These capacitors act as a filter and therefore prevent the laser output from changing too rapidly. This gives added laser diode protection. This also limits the laser output bandwidth to about 10 kHz. In the Low Bandwidth - CW mode, the bandwidth is further limited to 30 Hz.

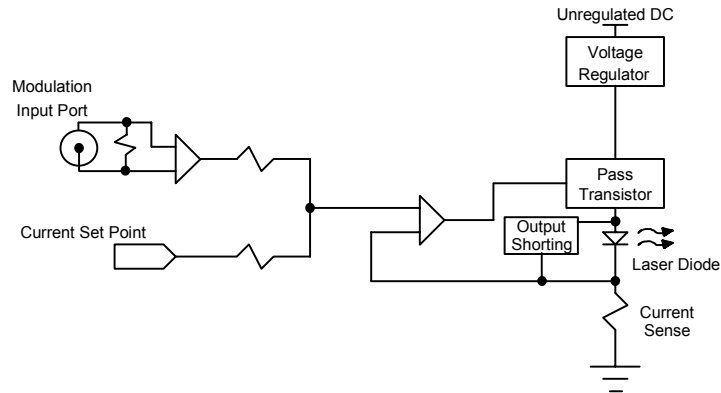

**Figure 21 - Constant Current - High Bandwidth Mode**

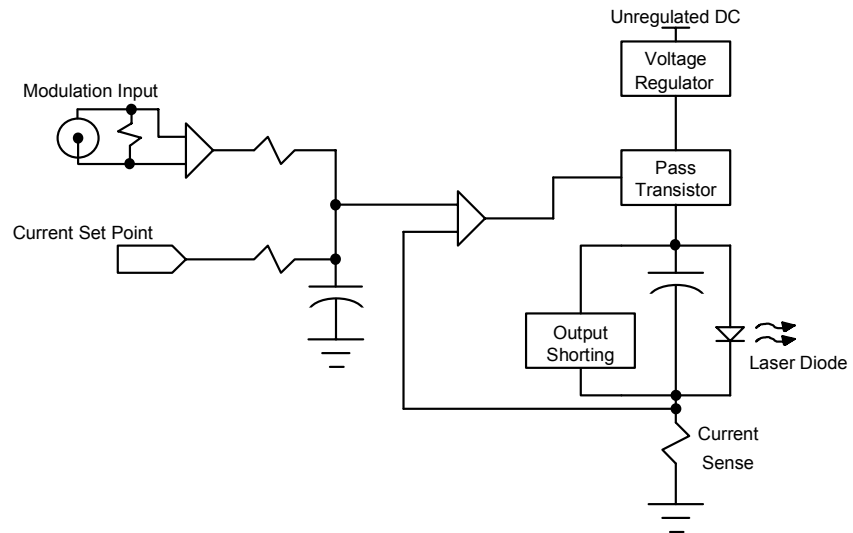

Figure 22 - Constant Current - Low Bandwidth Mode

### 3.6.11 Constant Power Mode

In constant P mode the laser circuit is configured as shown in Figure 23. Photodiode feedback is used to control the laser output and the bandwidth is held low.

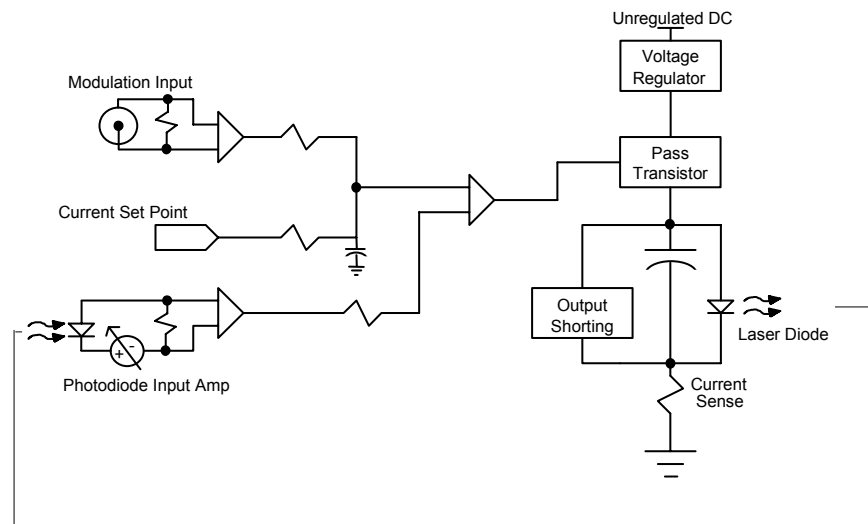

Figure 23 - Constant Power Mode

### 3.6.12 Laser Interlock Operation

The back panel laser input/output connector has interlock connections which must be connected before the laser output will be enabled.

On the laser input/output connector pins 1 and 2 form the interlock path. If there is not a connection between these pins the laser output will not be enabled. When this path is broken, the laser Interlock Error condition/event will be reported in the laser Condition Status Register and the Laser Event Status Register.

This interlock is a safety feature for laser protection. It requires that the connecting cable be secure before the laser output is enabled. A secure connection significantly reduces the possibility of an intermittent open circuit to the laser drive current.



## 4. Temperature Controller Module Operation

### 4.1 Temperature Controller (TEC) Module

---

#### 4.1.1 Introduction

The 8300 and 8600 Series Temperature Control Modules are precision thermoelectric cooler control modules for use in the 8000 Modular Controller. It may be installed in any of the channel slots on the rear of the 8000, and may be interchanged with any other.

Features of the 8300 and 8600 Series include:

- Service-free modularity (calibration information is stored on the module)
- Close-case calibration
- Operational with most thermistors, IC and RTD temperature sensors
- Flexible setup with 8000 Save/Recall front panel functions
- High temperature stability
- Current Limit

#### 4.1.2 Installation

This section describes the procedures for installing and removing a Model 8000 compatible module from the 8000.

#### NOTE

The save/recall bin information will be lost upon detecting any change in the module configuration (such as installing a new module).

#### CAUTION

Although ESD protection is designed into the module, operation in a static-free work area is recommended.

#### CAUTION

Do not plug-in or unplug a module with the AC power on.

To install the module into the 8000, follow these steps:

1. **Turn the 8000 power off.** Installing a module with the 8000 on can damage the module and the 8000.
2. Place the module into an open bay on the back of the 8000 and slide the module into place. There are tracks at the top and bottom of the bay which guide the module into place. Screw the Module Locking Screws into the back panel to secure the module.

To remove the module from the 8000 follow these steps:

1. **Turn the 8000 power off.** Removing a module with the 8000 on can damage the module and the 8000.
2. Unscrew the Module Locking Screws which secure the module to the 8000 back panel.
3. Grasp the module by handle which extends from the bottom of the back panel. Gently, but firmly, pull the module out of the 8000.

---

## 4.2 TEC Safety Features

---

### 4.2.1 Conditions Which Will Automatically Shut Off the TEC Output

- High Temperature Limit
- Low Temperature Limit
- R Limit
- Sensor Open
- TEC Module Open
- Sensor Select changed
- Sensor Shorted
- Any Linked Functions

With the exception of the linked functions, each of these conditions can be disabled by clearing the appropriate bits in the TEC OUTOFF register. See the *Computer Interfacing Manual* for additional information.

---

## 4.3 The TEC Connectors

---

On the TEC Module, a 15-pin D-connector is used for input and output connections to the series 700 mounts, as shown by the pin-out diagram below.

---

<b>Pin</b>	<b>Description</b>
1,2	TE+
3,4	TE-
5,6	Ground
7	Sensor+
8	Sensor-

**Table 4 - TEC Connector Pinouts**

### **4.3.1 TEC Grounding Consideration**

The TEC output of the module is isolated from chassis ground, allowing either output terminal to be grounded at the user's option.

## **4.4 TEC Module Operation**

---

### **4.4.1 Quick Start**

After the power-on sequence is complete, the 8000 goes to the Master display. To set up a TEC module, press the **MENU** button, then the **Modules** soft key, then select the slot that the module resides in, and finally, the **Setup** soft key. At this point, the display shows all TEC parameters. Using the cursor keys, the numerical keypad, knob and ENTER, select the desired functions and set the parameter values. When finished, return to TEC display with **Prev** (previous) soft key.

Enter the desired set point value using the numerical key pad and ENTER, or use the knob. Press the **OFF** soft key to operate the TEC. The **OFF** changes to **ON**. To turn the TEC off, press the **ON** soft key.

### **4.4.2 TEC Main Screen**

The TEC main screen is shown Figure 24 and described below.

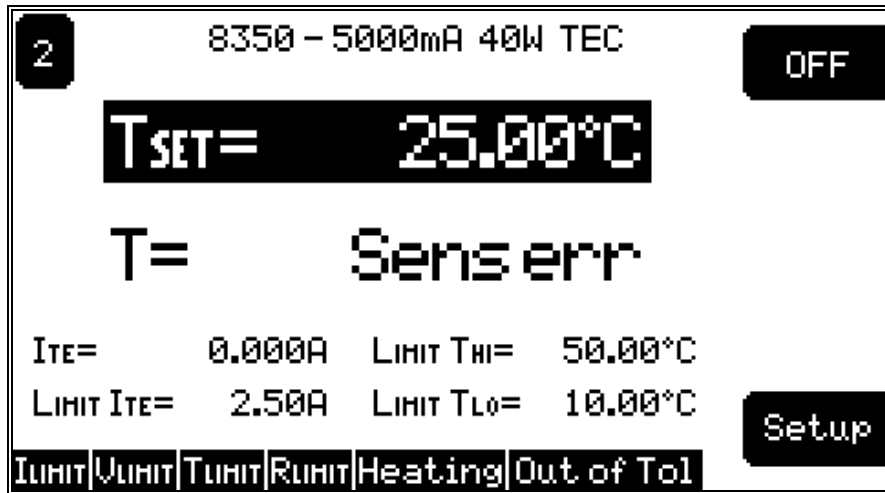

Figure 24 - TEC Main Screen

**ISET=, TSET=, RSET=, iSET=, and vSET=** - Indicates the set point value of current, temperature resistance, AD590 sensor current, or LM335 sensor voltage. In the screen shown above, the **TSET** is shown. **ISET, RSET, iSET=, and vSET=** would be seen when operating in those modes. Set point can be changed with numeric keys or the knob.

**I=, T=, R=, i=, and v=** - Indicates the measured value of current, temperature or resistance. A **Sens err** indicates a sensor error, usually caused by the sensor not hooked up or the wrong sensor selected. In the screen shown above, the **T** is shown. **I, R, i, and v** would be seen when operating in those modes.

**OFF/ON** - Indicates the state of the TEC output. Pushing the adjacent soft key toggles the state.

**Setup** - Pushing the adjacent soft key activates the setup screen.

The bottom line on the display has 6 “LED” elements, each indicating a particular state of the laser. They are defined as:

<b>ILIMIT</b>	When illuminated, indicates the TEC module is in current limit.
<b>VLIMIT</b>	When illuminated, indicates the TEC module has reached it's voltage limit.
<b>TLIMIT</b>	When illuminated, indicates the TEC module is outside the temperature limits defined by THI and TLO in the setup screen.
<b>RLIMIT</b>	When illuminated, indicates the TEC module is outside the reference limits defined by RHI/vHI/iHI and RLO/vLO/iLO in the setup screen.

**Heating/Cooling** When illuminated, indicates that the TEC is heating or cooling.  
**Out of Tol** When illuminated, indicates that the TEC is out of tolerance as defined by **Tol Time** and **Tol Temp** in the setup screen.

### 4.4.3 TEC Setup Screen

The TEC Setup screen is shown in Figure 25. Each section is described below in detail.

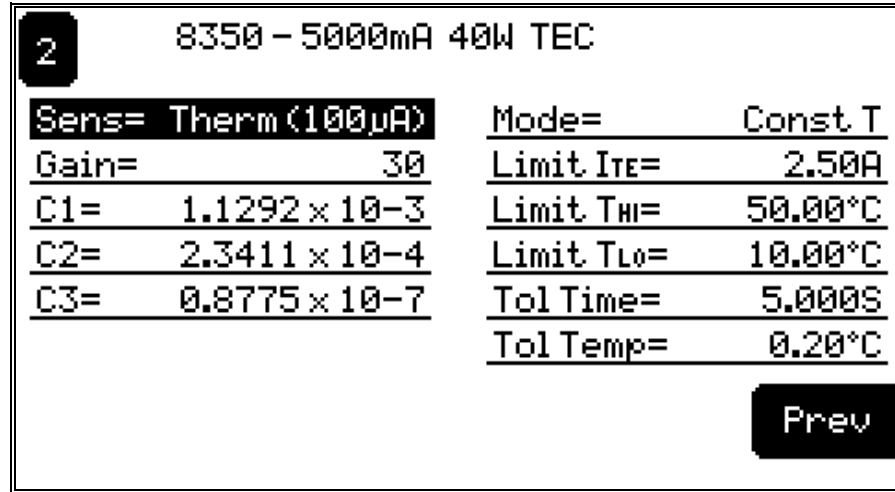

Figure 25 - TEC Setup Screen

#### 4.4.3.1 Sensor

Selects the temperature sensor type used in your TEC mount. If the **None** type (not available in the dual TEC module) is selected, only the ITE mode is allowed. This type is intended for applications running without a temperature sensor. After selecting desired sensor. See the following sections for discussions of the various sensor types. All TEC modules support the thermistor sensors (10µA and 100µA range). Single channel TEC modules add support for the AD590, LM335, and RTD sensors.

#### 4.4.3.2 Gain

The Gain function controls two parameters of the hybrid PI control loop; proportional gain and integration time.

When the actual temperature and the set point are different, an error voltage is generated. This error voltage is directly related to the difference in the actual and set point temperatures. The error voltage is then amplified by the proportional gain. This amplified error voltage controls the amount of current driven through the TEC.

The higher the gain, the more current will be driven for any given temperature difference, with the maximum current being determined by the current limit.

The error voltage also drives an integrator. The integrator's output also controls the amount of current being driven through the TEC. The integrator is an amplifier whose gain is proportional to time. The longer a given error voltage is present, the more current will be driven through the TEC, with the maximum current being determined by the current limit. The speed at which the integrator's output increases is the integration time, which can be "Slow" or "Fast". Some TEC modules do not support the Slow setting, and therefore omit the Fast designator in the range of settings.

The allowed Gain values are: 0.2 Slow, 0.6 Slow, 1 Slow, 1 Fast, 2 Slow, 3 Fast, 5 Fast, 6 Slow, 10 Slow, 10 Fast, 20 Slow, 30 Fast, 50 Fast, 60 Slow, 100 Fast or 300 Fast. The number actually defines the proportional loop gain. The slow/fast suffix indicates the speed at which the integrator's output increases. The slow setting allows for larger masses or greater distance between the sensor and the thermo-electric cooler by slowing the speed of the integrator.

Both the proportional gain and the integration time must be matched to the thermal characteristics of the TE cooler and sensor. If the settings are incorrect, the temperature set point will take an excessive amount of time to settle, or it will oscillate around the set point and never settle.

The Gain setting depends on the type of TE cooler that you are using, but we can suggest guidelines for selecting the proper gain. Set the gain to 1 fast and increase it until the actual temperature oscillates around the set temperature. Then reduce the gain to the next lower value.

To read the Gain setting, go to the setup. The display will show the value of the Gain setting. In Constant  $I_{TE}$  mode the Gain setting has no effect.

#### **4.4.3.3 C1, C2, C3, and Ro**

See the section of each of the sensors for a description of how C1, C2, C3, and Ro are used.

#### **4.4.3.4 Mode**

##### **4.4.3.4.1 Constant Temperature Mode (Const T)**

This mode holds the TEC at a constant temperature based on feedback from the sensor in the TEC mount, using "TSET=" and "T=" variables. In this mode, the 8000 uses a control loop comparing the sensor input to the temperature set point, driving the ITE current positive or negative to reach and maintain that set point. The sensor's input is converted to temperature for display of actual TEC temperature. The ITE current is also displayed in this mode.

#### 4.4.3.4.2 Constant Resistance/Reference Mode (Const R/Const v/Const i)

This mode operates identically to the Const T mode, but the sensor input is not converted to temperature, but is displayed in unconverted form. Likewise, the set point is used directly, not converted from temperature. Thermistor and RTD sensors use resistance (Const R mode, “RSET=” and “R=” variables), LM335 sensors use millivolts (Const v mode, “vSET=” and “v=” variables), and AD590 sensors use microamps (Const i mode, “iSET=” and “i=” variables).). Const R, Const v, and Const i are primarily intended for users who know a sensor set point in “sensor” units, not in °C. ITE current is also displayed in these modes. Const v and Const i modes are not supported on dual or combination TECs, as the sensors required for these modes are not supported.

#### 4.4.3.4.3 Constant Current Mode (Const ITE)

Unlike the modes above, the Const ITE mode allows the operator to explicitly set the amount and direction of current flow through the TEC, using “ISET=” and “ITE=” variables. If a sensor has been selected, the TEC temperature will be displayed. Although temperature is not a factor in the amount or direction of current flow, the high and low temperature limits are observed, and will shutdown the output if exceeded, in Const ITE mode if a sensor is selected. For no temperature limits, set the sensor type to “None.” Use caution when limits are not active, as the temperature may exceed your TEC or Laser’s thermal limits. Const ITE mode is not supported on dual or combination TECs.

#### 4.4.3.4.4 Effects of Calibration on TEC modes

On startup, the 8300/8600 performs an auto-calibration to eliminate most of the error in ADC and DAC values. After this auto-calibration, each sensor type supported by the module has an offset calibration, while the ITE set point and read back has a two point calibration. These calibration constants are then used to calibration a set point or read back value. This includes “cross-mode” values, such as displaying actual current while in constant temperature mode. While the current *set point* calibration has no effect in Const T mode, the *read back* calibration is used to more accurately display the actual current.

#### 4.4.3.5 Limits

##### 4.4.3.5.1 TE Current Limit (Limit ITE)

This sets the maximum drive current the module will allow. This maximum applies to all modes (constant ITE/R/T).

##### 4.4.3.5.2 Temperature Limits (Limit THi and Limit TLo)

The 8300/8600 supports both a low and high temperature limit, and can be programmed to turn the TEC output off in the event those limits are exceeded (default state). The temperature limits are monitored regardless of the mode of the module. This has the added safety feature of shutting down the module in Const ITE

or Const R mode when the temperature limit is exceeded (if the output off bits are enabled for this condition).

Caution: these limits do not apply if the sensor type is set to “None.”

#### 4.4.3.5.3 Resistance/Reference Limits (Limit RH/VH/IH and Limit RLO/VLO/iLO)

Like the temperature limits, the 8300/8600 also supports both a low and high resistance/reference limit, and can be programmed to turn the TEC output off in the event those limits are exceeded, although by default this is disabled. These limits are monitored only while in Const R/v/i mode.

#### 4.4.3.6 Tolerances (Tol Time and Tol Temp)

The **Tol Time** and **Tol Temp** elements are used for determining when the 8300 is “in tolerance,” where the actual temperature has stayed within **Tol Temp** of the set point for at least **Tol Time** seconds. The **Tol Time** value is expressed in seconds, and can range from 0.001 seconds to 50 seconds. The **Tol Temp** value is displayed in °C (the most common usage), and can range from 0.01 to 10.00. If at any time it goes outside the tolerance range, the time restarts at zero.

As an example, if the **Tol Time** is set to 5 seconds, the **Tol Temp** is set to 0.2°C, and the temperature set point was 25.0°C, the TEC module would have to stay within 24.8°C and 25.2°C to be within tolerance. Out of tolerance is indicated by a **Out Of Tol** status field on the bottom of the TEC Main Screen.

The out of tolerance condition is most often used to shutdown laser outputs when a TEC is not operating within tolerance. This can be done in one of two ways. The first, and simplest, would be to define a link condition with the TEC module as the source, **Out of Tol** as the condition, **Turn Off** as the action, and the laser module as the target.

Alternately, if the system was being operated over IEEE-488 or RS-232, once the TEC was within tolerance, its OUTOFF register could be set to turn the TEC off when out of tolerance. Then enable the TEC OFF bit in the laser’s OUTOFF register. This will cause the TEC to shutdown when it goes out of tolerance, and the laser to shutdown because the TEC is OFF. The disadvantage of this second method would be that the laser would shutdown if *any* TEC were off, which might not be the desired operation. Also, you would have to disable the Out of Tolerance bit in the TEC’s OUTOFF register before you could turn the TEC back on.

#### 4.4.3.7 Prev soft key

Pushing the **Prev** soft key returns to the previous screen.

#### 4.4.4 Link Conditions

The Laser module supports the following link conditions:



<i>Condi tion</i>	<i>Description</i>
<b>On</b>	TEC output is on
<b>Off</b>	TEC output is off
<b>Out Tol</b>	TEC is out of tolerance
<b>In Tol</b>	TEC is in tolerance
<b>I Lim</b>	TEC is current limiting
<b>V Lim</b>	TEC has reached its voltage limit
<b>T Lim</b>	TEC has exceeded temperature limit (low or high)
<b>Th Lim</b>	TEC has exceeded high temperature limit
<b>Tl Lim</b>	TEC has exceeded low temperature limit
<b>R Lim</b>	TEC has exceeded R limits (high or low)
<b>Open</b>	TEC module is open

**Table 5 - TEC Link Conditions**

See the section in the main Model 8000 manual of linking for a complete description of the linking process.

## **4.5 Sensors**

### **4.5.1 Thermistor and Thermistor Current Selection**

#### **4.5.1.1 Introduction**

Choosing the right sensing current depends on the range of temperature you want to measure and the resolution you require at the highest measured temperature. To correctly set the thermistor current you must understand how the thermistor and the 8000 interact and how temperature range and resolution values are inherent in the nature of thermistors.

#### **4.5.1.2 Thermistor Range**

Thermistors can span a wide temperature range, but their practical range is limited by their non-linear resistance properties. As the sensed temperature increases, the resistance of the thermistor decreases significantly and the thermistor resistance changes less for an equivalent temperature change. Consider the temperature and sensitivity figures below.

<u>Temperature</u>	<u>Sensitivity</u>
-20°C	5600 ohms/°C
25°C	439 ohms/°C
50°C	137 ohms/°C

In the 8000 the practical upper temperature limit is the temperature at which the thermistor becomes insensitive to temperature changes. The lower end of the temperature range is limited by the maximum A/D input voltage of the 8000. Thermistor resistance and voltage are related through Ohm's Law ( $V = I \times R$ ). The 8000 supplies current to the thermistor, either  $10 \mu\text{A}$  or  $100 \mu\text{A}$ , and as the resistance changes a changing voltage signal is available to the thermistor inputs of the 8000. The 8000 will over-range when the input voltage exceeds about 5 Volts. Figure 26 graphically shows the lower temperature and upper voltage limits for a typical 10 k Ohm thermistor. The practical temperature ranges for a typical 10 K thermistor (a 10 K thermistor has a resistance of 10 k Ohms at  $25^\circ\text{C}$ ) are given in the table below.

<u>Sensing Current</u>	<u>Temperature Range</u>
$10 \mu\text{A}$	$-51$ to $40^\circ\text{C}$
$100 \mu\text{A}$	$-10$ to $100^\circ\text{C}$

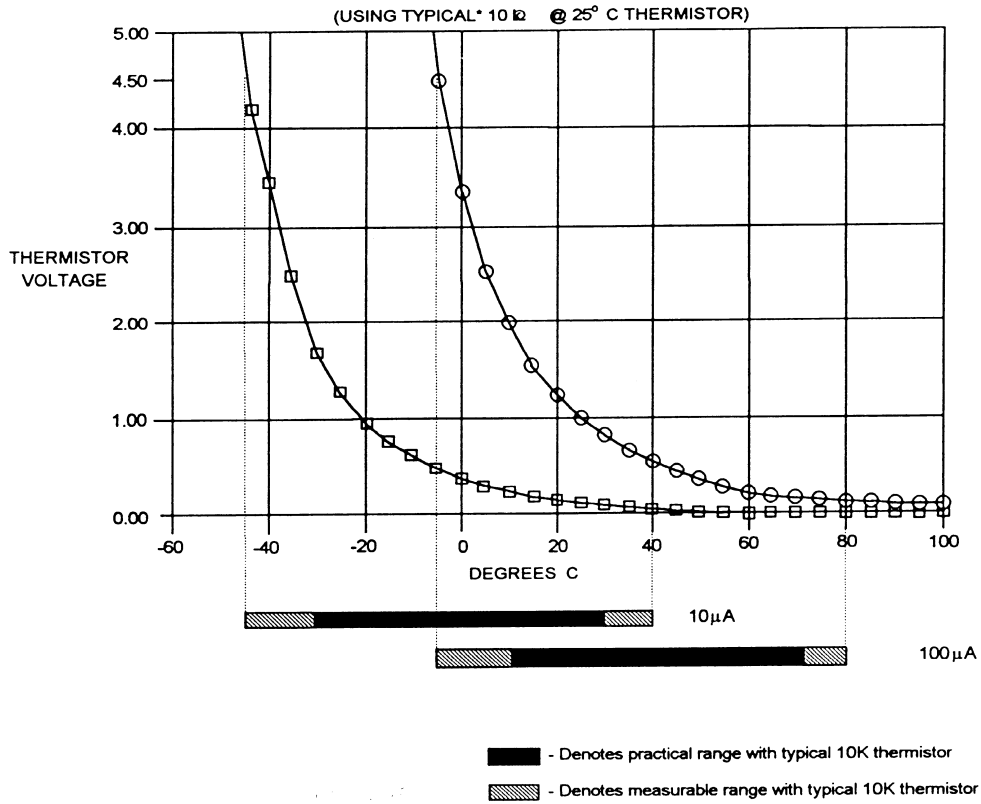

Figure 26 - Thermistor Temperature Range

### 4.5.1.3 Temperature Resolution

You must also consider measurement resolution since the resolution decreases as the thermistor temperature increases. The 8000 uses an A/D converter that has a maximum resolution of about 76  $\mu\text{V}$ . The microprocessor converts this digital number to resistance, stores this resistance, then converts it to a temperature using the Steinhart-Hart equation, and stores this temperature. A temperature change of one degree centigrade will be represented by a greater resistance increase (and therefore more A/D counts) at a lower temperature than at a higher temperature because of the non-linear resistance of the thermistor. Resolution figures for a typical 10 k Ohm thermistor are given below.

<u>Temperature</u>	<u>Voltage at 10 <math>\mu\text{A}</math></u>	<u>Resolution</u>
-20 °C	56.0 mV/°C	0.018 °C/mV
25 °C	4.4 mV/°C	0.230 °C/mV
50 °C	1.4 mV/°C	0.700 °C/mV

For this thermistor, a temperature change from -20°C to -19°C will be represented by 737 A/D counts (if supplied with 10 $\mu\text{A}$ ). The same thermistor will only change about 18 A/D counts from 49°C to 50°C.

### 4.5.1.4 Selecting Thermistor Current

To select the current setting for a typical 10 K thermistor, determine the lowest temperature you will need to sample and select the current according to the range limits given above. If the temperature you want to sample is below -10°C you should use the 10 $\mu\text{A}$  setting.

With the current set to 10 $\mu\text{A}$  the best resolution you will see will be a 1.0°C temperature change. If, for example, the lower limit is 0°C you can choose either setting, but there is a tradeoff in terms of resolution. If you need better than 0.1°C measurement resolution you will have to change to 100 $\mu\text{A}$ .

If you need high resolution over a narrow range, for a very accurate measurement, you can set the current setting for the maximum resolution. For example, at a high temperature of 15°C, you require a measurement resolution of at least 0.05°C. This resolution is within the range of either setting, but at the 10 $\mu\text{A}$  setting the resolution is only 0.2°C while at the 100  $\mu\text{A}$  setting the resolution is better than .05 °C.

Generally, it is best to use the 100 $\mu\text{A}$  setting for all measurements of -10°C or greater with a 10 K thermistor.

### 4.5.1.5 Selecting Thermistors

The type of thermistor you choose will depend primarily on the operating temperature range. These guidelines for selecting the range and resolution will apply

to any thermistor. 10 K thermistors are generally a good choice for most laser diode applications where high stability is required near room temperatures. Similarly, 10 K thermistors are often a good choice for cooling applications where you want to operate at temperatures from -40°C to room temperature.

If you require a different temperature range or the accuracy you need can't be achieved with either current setting, select another thermistor. Thermistor temperature curves, supplied by the manufacturer, show the resistance verses temperature range for many other thermistors. Newport, Inc. will also offer help for your specific application.

#### 4.5.1.6 The Steinhart-Hart Equation

The Steinhart-Hart equation is used to derive temperature from the non-linear resistance of an NTC (Negative Temperature Coefficient) thermistor.

The following section contains an explanation of the Steinhart-Hart equation and the values of these constants for some common thermistors.

Two terminal thermistors have a non-linear relationship between temperature and resistance. The resistance verses temperature characteristics for a family of similar thermistors is shown in Figure 27. It has been found empirically that the resistance verses temperature relationship for most common negative temperature coefficient (NTC) thermistors can be accurately modeled by a polynomial expansion relating the logarithm of resistance to inverse temperature. The Steinhart-Hart equation is one such expression and is given as follows:

$$1/T = A + B (\ln R) + C (\ln R)^3$$

Where T is in KELVIN. To convert T to °C, subtract 273.15.

Once the three constants A, B, and C are accurately determined, only small errors in the calculation of temperature over wide temperature ranges exist. Table 6 shows the results of using the equation to fit the resistance verses temperature characteristic of a common 10 k Ohm (at room temperature) thermistor. The equation will produce temperature calculation errors of less than 0.01°C over the range -20°C to 50°C.

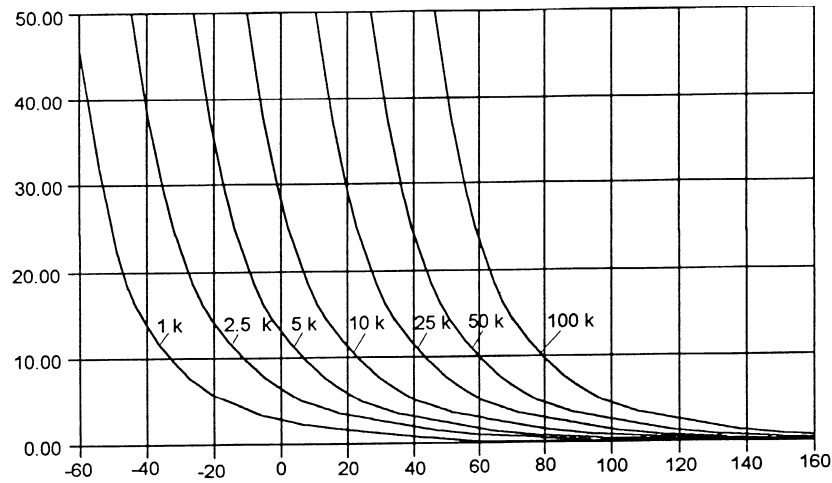

**Figure 27 - Thermistor Resistance versus Temperature**

-----Error T (°C)-----

$R^1$	T Actual	First Order Fit. Eq. 2 <sup>2</sup>	Third Order Fit. Eq. 1 <sup>3</sup>
97072	-20.00	-0.00	-0.32
55326	-10.00	0.00	-0.06
32650	0.00	-0.00	0.09
19899	10.00	-0.00	0.15
12492	20.00	-0.00	0.13
10000	25.00	0.00	0.08
8057	30.00	0.00	0.01
5326	40.00	0.00	-0.20
3602	50.00	-0.00	-0.50

**Table 6 - Comparison of Curve Fitting Equations**

In practice we have found that the constants A, B and C for virtually all common thermistors lie within a narrow range. Consequently, we have defined the constants C1, C2, C3 as follows:

$$C1 = A * 10^{+3}$$

<sup>1</sup> Resistance of a 10K, Fenwal UUA41J1 thermistor.

<sup>2</sup> Constants  $A' = 0.963 * 10^{-3}$ ,  $B' = 2.598 * 10^{-4}$

<sup>3</sup> Constants  
 $A = 1.125 * 10^{-3}$  (C1 = 1.125)  
 $B = 2.347 * 10^{-4}$  (C2 = 2.347)  
 $C = 0.855 * 10^{-7}$  (C3 = 0.855)

$$C2 = B * 10^{+4}$$

$$C3 = C * 10^{+7}$$

The constants C1, C2, and C3 may all be expressed in the form n.nnn simplifying entry into the 8000.

If high accuracy is not required, the Steinhart-Hart equation may be simplified to a first order polynomial:

$$1/T = A' + B' * \ln R$$

This equation is easier to solve and often provides adequate results. The table also shows that the use of the simplified equation introduces temperature errors of less than 0.5°C over the range -20°C to 50°C. Once the constants A' and B' are determined, the 8000 is programmed with the following values of C1, C2 and C3:

$$C1 = A' * 10^{+3}$$

$$C2 = B' * 10^{+4}$$

$$C3 = 0.000$$

#### 4.5.1.7 Table of Constants

We have listed some common thermistors and included the appropriate calibration constants for the temperature range -20°C to 50°C in Table 7. The Model 8000, by default, uses the BetaTHERM 10K3A2 thermistor values.

<i>Manufacturer</i>	<i>C1</i>	<i>C2</i>	<i>C3</i>
<b>BetaTHERM 10K3</b>	<b>1.129241</b>	<b>2.341077</b>	<b>0.877547</b>
BetaTHERM 0.1K1	1.942952	2.989769	3.504383
BetaTHERM 0.3K1	1.627660	2.933316	2.870016
BetaTHERM 1K2	1.373419	2.771785	1.999768
BetaTHERM 1K7	1.446659	2.682454	1.649916
BetaTHERM 2K3	1.498872	2.379047	1.066953
BetaTHERM 2.2K3	1.471388	2.376138	1.051058
BetaTHERM 3K3	1.405027	2.369386	1.012660
BetaTHERM 5K3	1.287450	2.357394	0.950520
BetaTHERM 10K3	1.129241	2.341077	0.877547
BetaTHERM 10K4	1.028444	2.392435	1.562216
BetaTHERM 30K5	0.933175	2.213978	1.263817
BetaTHERM 30K6	1.068981	2.120700	0.901954
BetaTHERM 50K6	0.965715	2.106840	0.858548
BetaTHERM 100K6	0.827111	2.088020	0.805620
BetaTHERM 1M9	0.740239	1.760865	0.686600

**Table 7 - Thermistor Constants**

#### 4.5.2 AD590 and LM335

AD590 and LM335 sensors are not supported on dual or combination TECs.

#### 4.5.2.1 General

The 8000 uses two constants (C1 and C2) for calibrating the two linear thermal sensing devices, the AD590 and the LM335. C1 is used as the zero offset value, and C2 is used as the slope or gain adjustment. Therefore, C1 has a nominal value of 0, and C2 has a nominal value of 1 when using the AD590 or LM335. In order to calibrate a linear sensor device, the sensor must be operated at an accurately known, stable temperature. For example, the sensor may be calibrated at 0°C if the sensor is placed in ice water until its temperature is stable. A highly accurate temperature probe, thermometer, environmental chamber, etc., may also be used to determine the known temperature for calibration.

#### 4.5.2.2 AD590 Sensor

The AD590 is a linear thermal sensor which acts as a current source. It produces a current,  $i$ , which is directly proportional to absolute temperature, over its useful range (-50°C to +150°C). This nominal value can be expressed as:

$$i = 1 \mu\text{A} / \text{K}$$

where  $i$  is the nominal current produced by the AD590, and  $K$  is in Kelvin.

The 8000 uses  $i$  to determine the nominal temperature,  $T_n$ , by the formula:

$$T_n = (i / (1 \mu\text{A} / \text{K})) - 273.15$$

where  $T_n$  is in °C.

The displayed temperature,  $T_d = C1 + (C2 * T_n)$ , is then computed, where  $C1$  and  $C2$  are the constants stored in the 8000 for the AD590. The AD590 grades of tolerance vary, but typically without adjusting  $C1$  and  $C2$ , the temperature accuracy is  $\pm 1^\circ\text{C}$  over its rated operating range. However, the AD590 is not perfectly linear, and even with  $C1$  accurately known there is a non-linear absolute temperature error associated with the device. This non-linearity is shown in Figure 28, reprinted from Analog Devices specifications, where the error associated with  $C1$  is assumed to be zero.

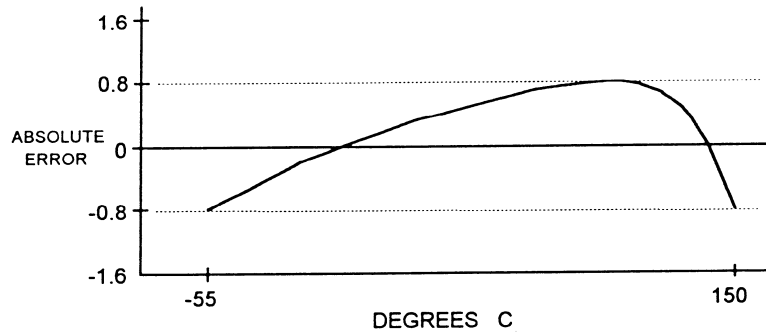

**Figure 28 - AD590 Nonlinearity**

If a maximum absolute error of 0.8°C is tolerable, the one point calibration of C1 should be used. If a greater accuracy is desired, the two point method of determining C1 and C2 should be used. Note however, the absolute error curve is non-linear, therefore the constant C2 will vary for different measurement points.

#### 4.5.2.3 LM335 Sensor

The LM335 is a linear thermal sensor which acts as a voltage source. It produces a voltage,  $v$ , which is directly proportional to absolute temperature, over its useful range (-40°C to +100°C). This nominal value can be expressed as:

$$v = 10\text{mV} / \text{K}$$

where  $v$  is the voltage produced by the LM335 and K is Kelvin.

The 8000 uses  $v$  to determine the nominal temperature,  $T_n$ , by the formula:

$$T_n = (v / (10\text{mV} / \text{K})) - 273.15$$

where  $T_n$  is in °C.

The temperature,  $T_d$ , which is displayed by the 8000 is calculated as follows:

$$T_d = C1 + (C2 * T_n)$$

where C1 and C2 are the constants stored in the 8000 for the LM335.

When the LM335 is calibrated to 25°C,  $C1 = 0$  and  $C2 = 1$ , and the temperature accuracy is typically  $\pm 0.5^\circ\text{C}$  over the rated operating range. However, the LM335 is not perfectly linear, and even with C1 accurately known there is a non-linear absolute



temperature error associated with the device. This non-linearity caused error is typically  $\pm 0.3^{\circ}\text{C}$ , with the error associated with C1 assumed to be zero.

If a maximum absolute error of  $\pm 0.3^{\circ}\text{C}$  can be tolerated, the one point calibration of C1 should be used. If a greater accuracy is desired, the two point method of determining C1 and C2 should be used. Note however, the absolute error associated with the constant C2 may vary over different temperature ranges.

#### 4.5.2.4 Determining C1 and C2 for the AD590 and LM335

The nominal values of C1 and C2 are 0 and 1, respectively, for both types of devices. These values should be used initially for determining C1 and C2 in the methods described below.

The One Point method is easiest, but it ignores the non-linearity of the device. It is most useful when a high degree of temperature accuracy is not required.

The Two Point method can achieve a high degree of accuracy over a narrower operating temperature range, but requires two accurate temperature measurements.

##### 4.5.2.4.1 One Point Calibration Method

The calibration described in this section is independent of the calibration procedure described in sections 6.3.4 and 6.3.6. Those sections deal with the internal calibration of the 8300 module, while the following calibration procedure is for calibrating the external AD590 or LM335 sensor. For the most accurate possible results, both calibration procedures should be performed.

The accuracy of this procedure depends on the accuracy of the externally measured temperature. It is used to determine the zero offset of the device, and it assumes that the gain (slope) is known.

1. Allow the 8000 to warm up for at least one hour. Select the desired sensor type in the setup menu.
2. Set the C1 parameter to zero. Set the C2 parameter to 1.
3. Place the sensor at an accurately known and stable temperature,  $T_a$ . Connect the sensor to the 8000 for normal Constant temperature operation. Allow the 8000 to stabilize at the known temperature,  $T_a$  and read the displayed temperature,  $T_d$ .
4. Determine the new value of C1 from the formula:

$$C1 = T_a - T_d$$

and enter the new C1 value.

#### 4.5.2.4.2 Two Point Calibration Method

The calibration described in this section is independent of the calibration procedure described in sections 6.3.4 and 6.3.6. Those sections deal with the internal calibration of the 8300 module, while the following calibration procedure is for calibrating the external AD590 or LM335 sensor. For the most accurate possible results, both calibration procedures should be performed.

The accuracy of this procedure depends on the accuracy of the externally measured temperature. It is used to determine the zero offset of the device and the gain (slope).

1. Allow the 8000 to warm up for at least one hour. Select the desired sensor type in the setup menu.
2. Set the C1 parameter to zero. Set the C2 parameter to 1.
3. Place the sensor at an accurately known and stable temperature,  $T_{a1}$ . Connect the sensor to the 8000 for normal Constant temperature operation. Allow the 8000 to stabilize at the known temperature,  $T_{a1}$  and read the displayed temperature,  $T_{d1}$ . Record these values.
4. Repeat Step 3 for another known temperature,  $T_{a2}$ , and the corresponding displayed temperature,  $T_{d2}$ . The two known temperatures should be at the bounds of the intended operating range. For best results, make the range between  $T_{a1}$  and  $T_{a2}$  as narrow as possible.
5. Determine the new value of C1 and C2 from the following calculations.

First determine the intermediate values U and V, where

$$C2 = (T_{a1} - T_{a2}) / (T_{d1} - T_{d2}), \text{ and}$$

$$C1 = T_{a1} - (T_{d1} * C2)$$

6. Enter the new C1 and C2 values.

#### 4.5.3 RTD Sensors

RTD sensors are not supported on dual or combination TECs.

The following equation is used in temperature to resistance conversions:

$$R_t = R_0 [1 + C1 \times t - C2 \times t^2 - C3 (t-100) t^3] \quad \text{for } t < 0^\circ\text{C}$$

$$R_t = R_0 [1 + C1 \times t - C2 \times t^2] \quad \text{for } t \geq 0^\circ\text{C}$$

where:  $R_t$  is the resistance in  $\Omega$  at temperature  $t$ .

t is the temperature in °C.

#### 4.5.3.1 RTD Constants

The constants entered for an RTD depend on the type of curve it has. Table 8 shows three standard types.

Curve	TCR ( $\Omega/\Omega/^{\circ}\text{C}$ )	C1	C2	C3	R0
Laboratory	.003926	$3.9848 \times 10^{-3}$	$-0.58700 \times 10^{-6}$	$4.0000 \times 10^{-12}$	100.00
US	.003910	$3.9692 \times 10^{-3}$	$-0.58495 \times 10^{-6}$	$-4.2325 \times 10^{-12}$	100.00
European	.003850	$3.9080 \times 10^{-3}$	$-0.58019 \times 10^{-6}$	$-4.2735 \times 10^{-12}$	100.00

**Table 8 - RTD Constants**

The R0 constant also applies for RTD sensors. It is nominally 100.00  $\Omega$ , but can be varied from 95.00  $\Omega$  to 105.00  $\Omega$ .

## 4.6 TEC Module Theory of Operation

Figure 29 shows the functionality of the TEC module. The following sections detail the theory of operation for each of the blocks in Figure 29.

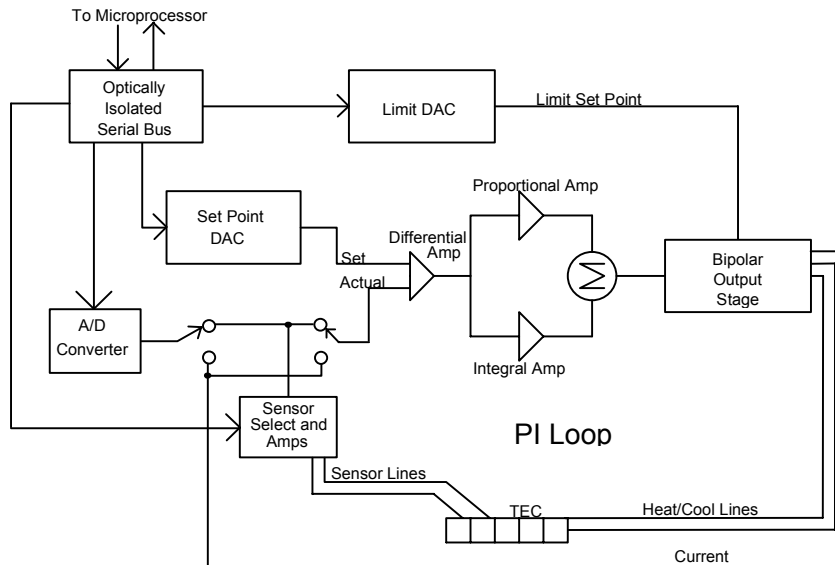

Figure 29 - TEC Board Module Diagram

### 4.6.1 TEC Interface

The TEC interface provides optically isolated serial communications between the TEC board and the microprocessor. Control signals are passed to the TEC board to set the TEC board status, current limit, and temperature set points. Instructions and data are sent over the serial interface to the optical barrier. Status and data are serially passed back to the microprocessor.

### 4.6.2 Limit DAC

The microprocessor loads the digitally stored current limit value into the current limit 12-bit DAC. The Limit DAC converts the digital limit signal from the microprocessor to a voltage which becomes the limit voltage for the Bipolar Output Stage. The current limit value is updated at power-up, at a "bin" recall, and whenever the LIM ITE value is changed.

### 4.6.3 Set Point DAC

The microprocessor loads the digitally stored current set point value into the set point 16-bit DAC. The Set Point DAC converts a digital set point signal from the microprocessor to a voltage which becomes the set temperature input to the PI control loop. The TEC current set point value is updated at power-up, at a "bin" recall, and whenever a TEC set point value is changed.

### 4.6.4 A/D Converter

The 16-bit A/D converter measures the sensor voltage and the current of the bipolar output stage. The sensor measurement is used by the microprocessor in the calculation of temperature or thermistor resistance. The current measurement is used for the ITE value.

### 4.6.5 Sensor Select

Sensor selection is accomplished in the Sensor Select block of the TEC board. Precision 100 $\mu$ A and 10 $\mu$ A current sources may be selected for thermistor control. RTD, LM335 and AD590 IC temperature sensors may also be selected. The AD590 has a +5 VDC bias voltage, the LM335 has a 1 mA bias current, and the RTD has a precision 1 mA current source.

The output of the Sensor Select block of the TEC board is a voltage which is proportional to the actual temperature. This voltage is fed to the A/D converter which provides a digital measurement to the microprocessor, and to the PI control loop to close the feedback loop when temperature is being controlled.

### 4.6.6 Difference Amplifier

Differential amp provides a proportional difference signal to the PI control. This signal is the difference between set temperature and actual temperature voltage.

### 4.6.7 Proportional Amplifier and Integrator

The proportional amplifier is part of a digitally controlled gain stage consisting of the analog switches and their associated resistors. The analog switches vary the ratio of resistance in the feedback circuit to change the gain.

The signal from the difference amplifier is sent to an integrator which reduces the difference between the set point temperature and the actual temperature to zero, regardless of the gain setting. An analog switch discharges the integrating capacitor whenever integration is not required to prevent unnecessary difference signal integration.

### 4.6.8 Bipolar Output Stage

The Bipolar Output Stage consists of circuits which limit the TEC output, sense the TEC output polarity, sense voltage and current limit conditions, as well as supply the

bipolar TEC output. The following sections discuss these functions of the Bipolar Output Stage.

#### **4.6.8.1 Current Limiting**

The output of the proportional amplifier and integrator together form the control signal. Output current limiting is effected by bounding the control signal so that it is always less than the limit current. The limit current is set with the front panel controls or through the GPIB. The bipolar current limit levels are established by the output of the current Limit DAC.

#### **4.6.8.2 Current Limit Condition Sensing**

Comparators sense the output to determine when output current limiting is occurring. When this condition occurs, the I Limit signal is sent to the microprocessor.

#### **4.6.8.3 Voltage Controlled Current Source**

The bounded output control signal is applied to an amplifier. This amplifier and the current sensing amplifier form the output voltage controlled current source. The output of this stage directly drives the externally connected TE cooler module.

#### **4.6.8.4 Voltage Limit Condition Sensing**

Comparators sense the output to determine when the TEC output compliance voltage limiting is occurring. This condition occurs whenever the TEC output is open or connected to a high resistance. If this condition occurs, the V Limit error signal is passed to the microprocessor.

### **4.6.9 TEC Control Modes**

The 8000 provides three control modes for operation, constant T (temperature), constant R (resistance, voltage, or current), and constant ITE (current) modes. Each of these modes is discussed in the following sections.

#### **4.6.9.1 T Mode**

In constant T mode the TEC is driven to the set point temperature. This temperature is monitored by the sensor in the TEC. In the case of a thermistor sensor, the thermistor's resistance is used to determine TEC's temperature by using the Steinhart-Hart conversion equation. The resistance is determined by measuring the voltage across the thermistor (with a known current of 10 $\mu$ A or 100 $\mu$ A). The ITE current is also measured and saved. The TEC's output current is sensed across a resistor and the voltage is converted to an ITE current value.

When an LM335 sensor is used, a two-point conversion equation is used to determine the temperature. Its voltage is measured as well as the ITE current.

When an AD590 sensor is used, another two-point conversion equation is used to determine the temperature. Its reference current is sensed across a resistor, and this voltage is measured. The ITE current is also measured.

#### **4.6.9.2 R Mode**

In constant R mode, the TEC is driven to the set point resistance, voltage, or current. This resistance, voltage, or current is measured and converted to a temperature. The ITE current is also measured.

#### **4.6.9.3 ITE Mode**

In constant ITE mode, the TEC is driven with a constant current, at the ITE set point value. The ITE current is sensed across a resistor and the voltage is converted to ITE current.





## 5. Maintenance

### 5.1 Introduction

---

Module specific calibration can be found in the module's manual. There is no calibration on the main frame. Do not attempt to remove the cover.

### 5.2 Fuse Replacement

---

The fuses are accessible on the back panel of the 8000. Before replacing a fuse, turn power off and disconnect the line cord. Use only the fuses indicated below.

<u>Line Voltage</u>	<u>Fuse Replacement</u>
90-110 VAC	5.00 Amp, 3 AG, Slo-Blo, 250V
108-132 VAC	5.00 Amp, 3 AG, Slo-Blo, 250V
198-242 VAC	2.50 Amp, 3 AG, Slo-Blo, 250V
216-250 VAC	2.50 Amp, 3 AG, Slo-Blo, 250V

### 5.3 Cleaning

---

Use mild soap solution on a damp but not wet cloth. Disconnect AC power before cleaning.



## 6. Calibration

### 6.1 Calibration Overview

---

The 8000 performs an automatic DAC calibration on power-up. This removes the majority of calibration error. However, if it is desired to completely calibrate the system, the following procedures will do so.

All calibrations are done with the case closed. The instrument is calibrated by changing the internally stored digital calibration constants.

All calibrations may be performed locally or remotely.

#### 6.1.1 Environmental Conditions

Calibrate this instrument under laboratory conditions. We recommend calibration at  $25^{\circ}\text{C} \pm 1.0^{\circ}\text{C}$ . When necessary, however, the 8000 may be calibrated at its intended use temperature if this is within the specified operating temperature range of  $0^{\circ}\text{C}$  to  $40^{\circ}\text{C}$ .

#### 6.1.2 Warm-Up

The 8000 should be allowed to warm up for at least 1 hour before calibration.

### 6.2 Laser Calibration

---

This chapter describes how to calibrate the 8500/8600 Series laser modules.

#### 6.2.1 Recommended Equipment

Recommended test equipment for calibrating the module is listed in Table 1. Equipment other than that shown in the table may be used if the specifications meet or exceed those listed.

<u>Description</u>	<u>Mfg./Model</u>	<u>Specification</u>
DMM	HP 34401A	DC Amps @ 1.0 A): $\pm 1\%$ Resistance (@ 10 ohms): 0.02%
Resistor	High Power, Low Temperature Coefficient	1 $\Omega$ , 50 W; 2 $\Omega$ , 25 W; 5 $\Omega$ , 10 W; 10 $\Omega$ , 5 W; 30 $\Omega$ , 2 W
Optical Isolator	NEC PS2501-1	or equivalent, 6-pin
Connector	D-sub	9-pin male

**Table 9 - Recommended Test Equipment**

## 6.2.2 Drive Current Load Resistor Selection

Laser Drive Current	Resistor
200 mA	30 $\Omega$ , 2 W
500 mA	10 $\Omega$ , 5 W
1,000 mA	5 $\Omega$ , 10 W
3,000 mA	2 $\Omega$ , 25 W
6,000 mA	1 $\Omega$ , 50 W

Table 10 - Drive Current Load Resistor Selection

## 6.2.3 Local Operation Current Source ( $I_o$ ) Calibration

- a. With the output off, connect a load resistor, as selected Table 10, and a calibrated ammeter in series across the laser output terminals. If an ammeter with the appropriate current ratings is unavailable, connect a calibrated DMM across the laser output terminals to measure the voltage across the resistor. Calculate the current in the following steps by using Ohm's Law:

$$I = V / R$$

where V is the measured voltage across the resistor, and R is the measured load resistance.

- b. Go to the single module display by first pressing the **MENU** button, then the **Modules** soft key, then the soft key(s) that correspond to the module to be calibrated.
- c. Press the **Setup** soft key and set the laser current limit ( **$I_o$  Lim**) to one-half scale plus 100 mA and output bandwidth as desired. Press the **Prev** soft key to return to the single display.
- d. Press the **OFF** soft key to turn the laser output on, if it is not on already.
- e. Go to the Calibration Screen. This is done by pressing the **Menu** button, **Config** soft key, **Calibrate** soft key; then the soft key(s) that correspond to the module to be calibrated.
- f. Press the the  **$I_o$**  soft key. Follow the on-screen instructions to complete the calibration. The calibration can be canceled without affecting the stored constants if the **Cancel** soft key is pressed at any point prior to completing the calibration.

## 6.2.4 Remote Operation Current Source (Io) Calibration

- a. With the output off, connect a load resistor, as selected Table 10, and a calibrated ammeter in series across the laser output terminals. If an ammeter with the appropriate current ratings is unavailable, connect a calibrated DMM across the laser output terminals to measure the voltage across the resistor. Calculate the current in the following steps by using Ohm's Law:

$$I = V / R$$

where V is the measured voltage across the resistor, and R is the measured load resistance.

- b. Select the channel [,subchannel] via the **LAS:CHAN** command. Set the current limit to one-half scale plus 100 mA via the **LAS:LIM:LDI** command, output bandwidth as desired via the **LAS:MODE:I**, **LAS:MODE:ICW**, or **LAS:MODE:ILBW** command, and current set point to one-half scale via the **LAS:LDI** command.
- c. Enter the **LAS:OUTPUT ON** command to turn the laser output on.
- d. Enter the laser LDI calibration mode by issuing the **LAS:CAL:LDI** command.
- e. Input the actual (measured) laser output current (as an <nrf value>) via the **LAS:LDI <nrf value>** command.

The 8000 will be ready to receive the current value when, after a **LAS:CAL:LDI?** query is sent, the response from the 8000 is "1".

- f. Once the actual current value is entered via the **LAS:LDI** command, the 8000 will apply a new current equal to approximately one-fourth (¼) the previous set point.

The 8000 will be ready to receive the second current value when, after a **LAS:CAL:LDI?** query is sent, the response from the 8000 is "1".

- g. Input the second actual (measured) laser output current as in Step e.
- h. Once the actual current value is entered via the second **LAS:LDI** command, the 8000 leaves the current calibration mode.

If, at any time prior to the second **LAS:LDI**, a command other than **LAS:LDI** or **LAS:CAL:LDI?** is sent to the 8000, the 8000 will cancel

the calibration mode and then process the command(s).

The **\*OPC?** query may be used to determine when the calibration is completed.

The operation complete flag (bit 0 of the Standard Event Status Register) may be used to trigger an interrupt. This type of interrupt is enabled by setting bit 0 of the Service Request Enable register and using the **\*OPC** command.

### 6.2.5 Local Operation $I_{PD}$ Current Calibration

This procedure calibrates the feedback circuits for constant  $I_{PD}$  and constant  $P_{PD}$  modes. The user enters the actual value of the current, as measured by an external DMM. The 8000 then automatically calibrates the laser feedback circuits. MOPA modules have photodiode feedback circuits on channel B only.

The  $I_{PD}$  calibration circuit is diagrammed below. Use Table 10 above to select a value for the R2 resistor that matches the maximum drive current of the laser diode module.

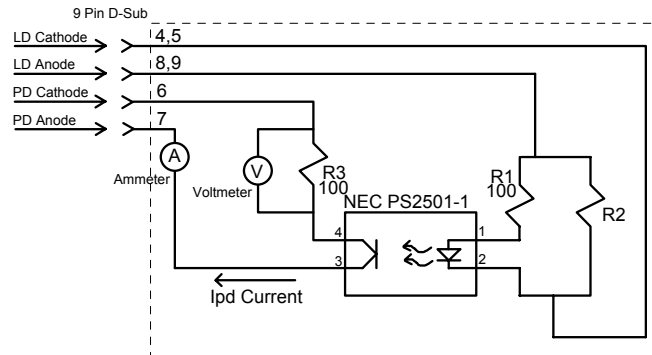

**Figure 30 -  $I_{PD}$  Calibration Circuit**

- a. With the laser output off, connect a calibrated ammeter to the PD Anode output of the module and connect the circuit of Figure 30 to the laser and PD outputs.

If a calibrated ammeter (with 0.1  $\mu\text{A}$  resolution) is not available, place a calibrated DMM (with 0.1 mV resolution) to measure the voltage across the resistor, R3, as shown in Figure 30. Calculate the current in the following steps by using Ohm's Law:

$$I = V / R$$

where V is the measured voltage across the resistor, and R is the measured load resistance.

- b. Go to the single module display by first pressing the **MENU** button, then the **Modules** soft key, then the soft key(s) that corresponds to the module to be calibrated.
- c. Press the **Setup** soft key, change the **Mode** to **Im** (Photodiode constant current mode), and set the laser current limit (**Io Lim**) to maximum. Press the **Prev** soft key to return to the single display.
- d. Press the **OFF** soft key to turn the laser output on. If a laser on delay has been set, wait that amount of time to allow the laser output to engage.
- e. Go to the Calibration Screen. This is done by pressing the **Menu** button, **Config** soft key, **Calibrate** soft key; then the soft key(s) that correspond to the module to be calibrated.
- f. Press the **Im** soft key. Follow the on-screen instructions to complete the calibration. The calibration can be canceled without affecting the stored constants if the **Cancel** soft key is pressed at any point prior to completing the calibration.

### 6.2.6 Remote Operation $I_{PD}$ Current Calibration

- a. With the laser output off, connect a calibrated ammeter to the photodiode anode output of the module and connect the circuit of Figure 30 to the laser and photodiode outputs.

If a calibrated ammeter (with 0.1  $\mu\text{A}$  resolution) is not available, place a calibrated DMM (with 0.1 mV resolution) to measure the voltage across the resistor, R3, as shown in Figure 30. Calculate the current in the following steps by using Ohm's Law:

$$I = V / R$$

where V is the measured voltage across the resistor, and R is the measured load resistance.

- b. Select the channel [,subchannel] via the **LAS:CHAN** command. Set the laser current limit to full scale via the **LAS:LIM:LDI** command. Set the photodiode current set point to  $\frac{1}{2}$  full scale via the **LAS:MDI** command. Place the unit into constant photodiode current mode via the **LAS:MODE:MDI** command.

- c. Enter the **LAS:OUTPUT ON** command to turn the laser output on.
- d. Enter the **LAS:CAL:MDI** command to place the 8000 in its laser photodiode current calibration mode.
- e. After a few seconds, the 8000 will be ready for the actual photodiode current to be entered via the **LAS:MDI** command. The measured value of the current should not be entered until the 8000 is ready to receive it.

The 8000 will be ready to receive the current value when, after a **LAS:CAL:MDI?** query is sent, the response from the 8000 is "1".

- f. Once the actual photodiode current value is entered via the **LAS:MDI** command, the 8000 will apply a new photodiode current equal to approximately one-fourth ( $\frac{1}{4}$ ) the previous set point.

The 8000 will be ready to receive the second current value when, after a **LAS:CAL:MDI?** query is sent, the response from the 8000 is "1".

- g. Input the second actual (measured) photodiode current as in Step e.
- h. Once the actual photodiode current value is entered via the second **LAS:MDI** command, the 8000 leaves the current calibration mode.

If, at any time prior to the second **LAS:MDI**, a command other than **LAS:MDI** or **LAS:CAL:MDI?** is sent to the 8000, the 8000 will cancel the calibration mode and then process the command(s).

The **\*OPC?** query may be used to determine when the calibration is completed.

The operation complete flag (bit 0 of the Standard Event Status Register) may be used to trigger an interrupt. This type of interrupt is enabled by setting bit 0 of the Service Request Enable register and using the **\*OPC** command.

### 6.2.7 Local Operation Laser Voltage Measurement Calibration

- a. With the output off, connect a calibrated voltmeter, in parallel with a load resistor, as selected Table 10, to the laser output terminals.
- b. Go to the single module display by first pressing the **MENU** button, then the **Modules** soft key, then the slot soft key that corresponds to the module to be calibrated.



- c. Press the **Setup** soft key and set the laser current limit (**I<sub>o</sub> Lim**) to 80% of the maximum current plus 100 mA and the laser voltage compliance limit (**Vcomp**) to 5.0 V, and output bandwidth as desired. Press the **Prev** soft key to return to the single display.
- d. Press the **OFF** soft key to turn the laser output on, if it is not on already.
- e. Go to the Calibration Screen. This is done by pressing the **Menu** button, **Config** soft key, **Calibrate** soft key; then the soft key(s) that correspond to the module to be calibrated.
- f. Press the **V<sub>f</sub>** soft key. Follow the on-screen instructions to complete the calibration. The calibration can be canceled without affecting the stored constants if the **Cancel** soft key is pressed at any point prior to completing the calibration.

### 6.2.8 Remote Operation Laser Voltage Measurement Calibration

- a. With the output off, connect a calibrated voltmeter, in parallel a load resistor, as selected Table 10, to the laser output terminals.
- b. Select the channel [,suchannel] via the **LAS:CHAN** command. Set the voltage limit to full scale via the **LAS:LIM:LDV** command, and the current set point necessary to read approximately 80% of full scale voltage. For example, with a 8560 module, with a resistance of 1  $\Omega$ , set the current to 4,800 mA. Place the unit into constant current mode via the **LAS:MODE:LDI** command.
- c. Enter the **LAS:OUTPUT ON** command to turn the laser output on.
- d. Enter the laser voltage calibration mode by issuing the **LAS:CAL:LDV** command.
- e. Input the actual (measured) laser voltage (as an <nrf value>) via the **LAS:LDV <nrf value>** command.

The 8000 will be ready to receive the value when, after a **LAS:CAL:LDV?** query is sent, the response from the 8000 is "1".

- f. Once the actual voltage value is entered via the **LAS:LDV** command, the 8000 will apply a new current equal to approximately one-fourth ( $\frac{1}{4}$ ) the previous set point.

The 8000 will be ready to receive the second voltage value when, after a **LAS:CAL:LDV?** query is sent, the response from the 8000 is "1".

- g. Input the second actual (measured) voltage as in Step e.
- h. Once the actual voltage value is entered via the **LAS:LDV** command, the 8000 leaves the current calibration mode.

If, at any time prior to the second **LAS:LDV**, a command other than **LAS:LDV** or **LAS:CAL:LDV?** is sent to the 8000, the 8000 will cancel the calibration mode and then process the command(s). The **\*OPC?** query may be used to determine when the calibration is completed.

The operation complete flag (bit 0 of the Standard Event Status Register) may be used to trigger an interrupt. This type of interrupt is enabled by setting bit 0 of the Service Request Enable register and using the **\*OPC** command.

## 6.3 TEC Calibration

This chapter describes how to calibrate the 8300/8600 Series modules.

### 6.3.1 Recommended Equipment

Recommended test equipment for calibrating the module is listed in Table 11. Equipment other than that shown in the table may be used if the specifications meet or exceed those listed.

<u>Description</u>	<u>Mfg./Model</u>	<u>Specification</u>
DMM	HP34401A	DC Amps @ 1.0 A): $\pm 1\%$ Resistance (@ 10 ohms): 0.02%
Resistors	Metal Film	10 k $\Omega$ for ITE calibration (dual/combo only) 20 k $\Omega$ for 100 $\mu$ A calibration 200 k $\Omega$ for 10 $\mu$ A calibration 3 k $\Omega$ for LM335 sensor calibration 16 k $\Omega$ for AD590 sensor calibration 100 $\Omega$ for RTD sensor calibration
Resistor	High Power	1 $\Omega$ , 50 W, for current calibration
Connector	D-sub	15-pin male

**Table 11 - Recommended Test Equipment**

### 6.3.2 Local Operation Thermistor Calibration

- a. Measure and record the exact resistance of your metal film resistor. Use nominal values of 20 k $\Omega$  for the 100 $\mu$ A setting, and 200 k $\Omega$  for the 10 $\mu$ A setting. With the TEC output off, connect the metal film resistor to the sensor input of the TEC Module.
- b. Go to the single module display by first pressing the **MENU** button, then the **Modules** soft key, then the slot soft key that corresponds to the module to be calibrated.
- c. Press the **Setup** soft key and select the appropriate thermistor (10 $\mu$ A or 100 $\mu$ A) as the Sensor Type. Press the **Prev** soft key to return to the single display.
- d. Go to the Calibration Screen. This is done by pressing the **Menu** button, **Config** soft key, **Calibrate** soft key; then the soft key(s) that correspond to the module to be calibrated.
- e. Enter the TEC sensor calibration mode by pressing the **Sensor** soft key. Follow the on-screen instructions to complete the calibration. The calibration can be canceled without affecting the stored constants if the **Cancel** soft key is pressed at any point prior to completing the calibration.

### 6.3.3 Remote Operation Thermistor Calibration

- a. Measure and record the exact resistance of your metal film resistor. Use nominal values of 20 k $\Omega$  for the 100 $\mu$ A setting, and 200 k $\Omega$  for the 10 $\mu$ A setting. With the TEC output off, connect the metal film resistor to the sensor input of the TEC Module.
- b. Enter the **TEC:CHAN** command to select the channel [,suchannel] to be calibrated. Send **TEC:SENS 1** 100 $\mu$ A thermistor, or **TEC:SENS 2** for the 10 $\mu$ A thermistor, followed by the **TEC:CAL:SEN** to enter sensor calibration mode.

The 8000 will be ready to receive the resistance when, after a **TEC:CAL:SEN?** query is sent, a "1" is returned.

- c. Input the actual resistance of the metal film resistor, in k $\Omega$ , (as an <nrf value>) via the **TEC:R <nrf value>** command.

If, at any time prior to **TEC:R**, a command other than **TEC:R** or **TEC:R?** is sent to the 8000, the 8000 will cancel the calibration mode

and then process the command(s).

Once the **TEC:R** value is sent, the **OPC?** query may be used to determine when the calibration is completed. The operation complete flag (bit 0 of the Standard Event Status Register) may be used to trigger an interrupt. This type of interrupt is enabled by setting bit 0 of the Service Request Enable register and using the **\*OPC** command.

### 6.3.4 Local Operation AD590 Sensor Calibration

- a. With the TEC output off, connect a precision 16 k $\Omega$  metal film resistor and a precision ammeter in series at the sensor input of the TEC Module.
- b. Go to the single module display by first pressing the **MENU** button, then the **Modules** soft key, then the slot soft key that corresponds to the module to be calibrated.
- c. Press the **Setup** soft key and select the AD590 as the Sensor Type. Press the **Prev** soft key to return to the single display.
- d. Go to the Calibration Screen. This is done by pressing the **Menu** button, **Config** soft key, **Calibrate** soft key; then the soft key(s) that correspond to the module to be calibrated.
- e. Enter the TEC sensor calibration mode by pressing the **Sensor** soft key. Follow the on-screen instructions to complete the calibration. The calibration can be canceled without affecting the stored constants if the **Cancel** soft key is pressed at any point prior to completing the calibration.

### 6.3.5 Remote Operation AD590 Sensor Calibration

- a. With the TEC output off, connect a precision 16 k $\Omega$  metal film resistor and a precision ammeter in series at the sensor input of the TEC Module.
- b. Enter the **TEC:CHAN** command to select the channel [,suchannel] to be calibrated. Enter the **TEC:SEN 4** and **TEC:CAL:SEN** to select the AD590 sensor and enter sensor calibration mode.

The 8000 will be ready to receive the current value when, after a **TEC:CAL:SEN?** query is sent, the response from the 8000 is "1".

- c. Input the actual current measured, in  $\mu\text{A}$ , by the external ammeter (as an <nrf value>) via the **TEC:R <nrf value>** command.

If, at any time prior to **TEC:R**, a command other than **TEC:R** or **TEC:R?** is sent to the 8000, the 8000 will cancel the calibration mode and then process the command(s).

Once the **TEC:R** value is sent, the **OPC?** query may be used to determine when the calibration is completed. The operation complete flag (bit 0 of the Standard Event Status Register) may be used to trigger an interrupt. This type of interrupt is enabled by setting bit 0 of the Service Request Enable register and using the **\*OPC** command.

### 6.3.6 Local Operation LM335 Sensor Calibration

- a. With the TEC output off, connect a 3 k $\Omega$  metal film resistor and a precision voltmeter in parallel at the sensor input of the TEC module.
- b. Go to the single module display by first pressing the **MENU** button, then the **Modules** soft key, then the slot soft key that corresponds to the module to be calibrated.
- c. Press the **Setup** soft key and select the LM335 as the Sensor Type. Press the **Prev** soft key to return to the single display.
- d. Go to the Calibration Screen. This is done by pressing the **Menu** button, **Config** soft key, **Calibrate** soft key; then the soft key(s) that correspond to the module to be calibrated.
- d. Enter the TEC sensor calibration mode by pressing the **Sensor** soft key. Follow the on-screen instructions to complete the calibration. The calibration can be canceled without affecting the stored constants if the **Cancel** soft key is pressed at any point prior to completing the calibration.

### 6.3.7 Remote Operation LM335 Sensor Calibration

- a. With the TEC output off, connect a 3 k $\Omega$  metal film resistor and a precision voltmeter in parallel at the sensor input of the TEC module.
- b. Enter the **TEC:CHAN** command to select the channel [,suchannel] to be calibrated. Enter the **TEC:SEN 3** and **TEC:CAL:SEN** to select the LM335 sensor and enter sensor calibration mode.

The 8000 will be ready to receive the voltage value when, after a **TEC:CAL:SEN?** query is sent, the response from the 8000 is "1".

- c. Input the actual voltage, in mV, measured by the external voltmeter (as an <nrf value>) via the **TEC:R <nrf value>** command.

If, at any time prior to **TEC:R**, a command other than **TEC:R** or **TEC:R?** is sent to the 8000, the 8000 will cancel the calibration mode and then process the command(s).

Once the **TEC:R** value is sent, the **OPC?** query may be used to determine when the calibration is completed. The operation complete flag (bit 0 of the Standard Event Status Register) may be used to trigger an interrupt. This type of interrupt is enabled by setting bit 0 of the Service Request Enable register and using the **\*OPC** command.

### 6.3.8 Local Operation RTD Calibration

- a. Measure and record the exact resistance of your 100  $\Omega$  metal film resistor. With the TEC output off, connect the metal film resistor to the sensor input of the TEC Module.
- b. Go to the single module display by first pressing the **MENU** button, then the **Modules** soft key, then the slot soft key that corresponds to the module to be calibrated.
- c. Press the **Setup** soft key and select the RTD as the Sensor Type. Press the **Prev** soft key to return to the single display.
- d. Go to the Calibration Screen. This is done by pressing the **Menu** button, **Config** soft key, **Calibrate** soft key; then the soft key(s) that correspond to the module to be calibrated.
- d. Enter the TEC sensor calibration mode by pressing the **Sensor** soft key. Follow the on-screen instructions to complete the calibration. The calibration can be canceled without affecting the stored constants if the **Cancel** soft key is pressed at any point prior to completing the calibration.

### 6.3.9 Remote Operation RTD Calibration

- a. Measure and record the exact resistance of your 100  $\Omega$  metal film resistor. With the TEC output off, connect the metal film resistor to the sensor input of the TEC Module.
- b. Enter the **TEC:CHAN** command to select the channel [,suchannel] to be calibrated. Send **TEC:SENS 5** to select the RTD sensor, followed by the **TEC:CAL:SEN** to enter sensor calibration mode.

The 8000 will be ready to receive the resistance when, after a **TEC:CAL:SEN?** query is sent, a “1” is returned.

- c. Input the actual resistance, in ohms, of the metal film resistor (as an <nrf value>) via the **TEC:R <nrf value>** command.

If, at any time prior to **TEC:R**, a command other than **TEC:R** or **TEC:R?** is sent to the 8000, the 8000 will cancel the calibration mode and then process the command(s).

Once the **TEC:R** value is sent, the **OPC?** query may be used to determine when the calibration is completed. The operation complete flag (bit 0 of the Standard Event Status Register) may be used to trigger an interrupt. This type of interrupt is enabled by setting bit 0 of the Service Request Enable register and using the **\*OPC** command.

### 6.3.10 RTD Lead Resistance Calibration (Offset Null)

Because the RTD sensor reflects changes in temperature with small changes in resistance, even a small lead resistance (resistance caused by the wire running between the TEC module and the RTD sensor) can cause significant temperature offset. The lead resistance may be taken out of the RTD reading as follows:

- a. With the TEC output off, short the sensor wires as close to the RTD sensor as possible.
- b. Go to the single module display by first pressing the **MENU** button, then the **Modules** soft key, then the slot soft key that corresponds to the module to be calibrated.
- c. Go to the Calibration Screen. This is done by pressing the **Menu** button, **Config** soft key, **Calibrate** soft key; then the soft key(s) that correspond to the module to be calibrated.
- c. Enter the TEC sensor calibration mode by pushing pressing the **RTD Null** soft key. Follow the on-screen instructions to complete the calibration. The calibration can be canceled without affecting the stored constants if the **Cancel** soft key is pressed at any point prior to completing the calibration.

### 6.3.11 Local Operation I<sub>TE</sub> Current Calibration

The following procedure is for calibrating the I<sub>TE</sub> constant current source for both polarities of current.

- a. With the output off, connect a 1  $\Omega$ , 50 W resistor and a calibrated ammeter in series across the laser output terminals. If an ammeter with the appropriate current ratings is unavailable, connect a 1  $\Omega$ , 50 W resistor across the laser output terminals and use a calibrated DMM to measure the voltage across the resistor. Calculate the current in the following steps by using Ohm's Law:

$$I = V / R$$

where V is the measured voltage across the resistor, and R is the measured load resistance. For dual and combination modules, also connect a 10 k $\Omega$  resistor across the sensor input.

- b. Go to the single module display by first pressing the **MENU** button, then the **Modules** soft key, then the slot soft key that corresponds to the module to be calibrated.
- c. Go to the Calibration Screen. This is done by pressing the **Menu** button, **Config** soft key, **Calibrate** soft key; then the soft key(s) that correspond to the module to be calibrated.
- c. Enter the TEC ITE calibration mode by pushing the **ITE** soft key. Follow the on-screen instructions to complete the calibration. The calibration can be canceled without affecting the stored constants if the **Cancel** soft key is pressed at any point prior to completing the calibration.

### 6.3.12 Remote Operation ITE Current Calibration, Single Channel TEC Modules

- a. With the output off, connect a 1  $\Omega$ , 50 W resistor and a calibrated ammeter in series across the laser output terminals. If an ammeter with the appropriate current ratings is unavailable, connect a 1  $\Omega$ , 50 W resistor across the laser output terminals and use a calibrated DMM to measure the voltage across the resistor. Calculate the current in the following steps by using Ohm's Law:

$$I = V / R$$

where V is the measured voltage across the resistor, and R is the measured load resistance.

- b. Enter the **TEC:CHAN** command to select the channel [,suchannel] to be calibrated. Send **TEC:CAL:ITE** to enter ITE calibration mode.



The module will be placed in ITE mode, limit set to 50% of full scale plus 100 mA, and the ITE set point set to 50% of full scale.

The 8000 will be ready to receive the first measured current value when, after a **TEC:CAL:ITE?** query is sent, a “1” is returned.

- c. Input the actual current (as an <nrf value>) via the **TEC:ITE <nrf value>** command. The 8000 will then drive the current to 25% of the initial set point.

The 8000 will be ready to receive the second measured current value when, after a **TEC:CAL:ITE?** query is sent, a “1” is returned.

- d. Input the second actual current (as an <nrf value>) via the **TEC:ITE <nrf value>** command. The 8000 will then drive the current to the negative current value of the initial set point.

The 8000 will be ready to receive the third measured current value when, after a **TEC:CAL:ITE?** query is sent, a “1” is returned.

- e. Input the third actual current (as an <nrf value>) via the **TEC:ITE <nrf value>** command. The 8000 will then drive the current to 25% of the negative current value of the initial set point.

The 8000 will be ready to receive the fourth measured current value when, after a **TEC:CAL:ITE?** query is sent, a “1” is returned.

- f. Input the fourth actual current (as an <nrf value>) via the **TEC:ITE <nrf value>** command.

If, at any time prior to the last **TEC:ITE**, a command other than **TEC:ITE** or **TEC:ITE?** is sent to the 8000, the 8000 will cancel the calibration mode and then process the command(s).

Once the **TEC:ITE** value is sent, the **OPC?** query may be used to determine when the calibration is completed. The operation complete flag (bit 0 of the Standard Event Status Register) may be used to trigger an interrupt. This type of interrupt is enabled by setting bit 0 of the Service Request Enable register and using the **\*OPC** command.

### 6.3.13 Remote Operation ITe Current Readback Calibration, Dual and Combo TEC Modules

Because the dual and combo modules only support constant temperature mode, calibration of the ITE readback is done using the limit circuit. By loading a 10 k $\Omega$  resistor across the sensor input and selecting the Thermistor sensor, the system will

read the temperature as a constant 25°C. Setting a temperature of 20°C and 30°C with the output on will force it to go to the positive and negative limit, respectively, allowing the limit set point to simulate an ITE current set point.

- a. Connect a 10 kΩ resistor across the sensor input. With the output off, connect a 1 Ω, 50 W resistor and a calibrated ammeter in series across the laser output terminals. If an ammeter with the appropriate current ratings is unavailable, connect a 1 Ω, 50 W resistor across the laser output terminals and use a calibrated DMM to measure the voltage across the resistor. Calculate the current in the following steps by using Ohm's Law:

$$I = V / R$$

where V is the measured voltage across the resistor, and R is the measured load resistance.

- b. Enter the **TEC:CHAN** command to select the channel [,suchannel] to be calibrated. Send **TEC:CAL:ITE** to enter ITE calibration mode.

The 8000 will select the Thermistor sensor and place the system in constant temperature mode. The ITE current limit is set to 50% of full scale, and the output turned on.

The 8000 will be ready to receive the first measured current value when, after a **TEC:CAL:ITE?** query is sent, a "1" is returned.

- c. Input the actual current (as an <nrf value>) via the **TEC:ITE <nrf value>** command. The 8000 will then drive the current to 25% of the initial set point. The 8000 will be ready to receive the second measured current value when, after a **TEC:CAL:ITE?** query is sent, a "1" is returned.
- d. Input the second actual current (as an <nrf value>) via the **TEC:ITE <nrf value>** command. The 8000 will then drive the current to the negative current value of the initial set point. The 8000 will be ready to receive the third measured current value when, after a **TEC:CAL:ITE?** query is sent, a "1" is returned.
- e. Input the third actual current (as an <nrf value>) via the **TEC:ITE <nrf value>** command. The 8000 will then drive the current to 25% of the negative current value of the initial set point. The 8000 will be ready to receive the fourth measured current value when, after a **TEC:CAL:ITE?** query is sent, a "1" is returned.

- f. Input the fourth actual current (as an <nrf value>) via the **TEC:ITE** <nrf value> command.

If, at any time prior to the last **TEC:ITE**, a command other than **TEC:ITE** or **TEC:ITE?** is sent to the 8000, the 8000 will cancel the calibration mode and then process the command(s). Once the **TEC:ITE** value is sent, the **OPC?** query may be used to determine when the calibration is completed. The operation complete flag (bit 0 of the Standard Event Status Register) may be used to trigger an interrupt. This type of interrupt is enabled by setting bit 0 of the Service Request Enable register and using the **\*OPC** command.



## 7. **Factory Service**

### 7.1 **Introduction**

---

This section contains information regarding obtaining factory service for the Model 8000. The user should not attempt any maintenance or service of this instrument and/or accessories beyond the procedures given in chapters 5 and 6. Any problems which cannot be resolved using the guidelines listed in chapters 5 and 6 should be referred to Newport Corporation factory service personnel. Contact Newport Corporation or your Newport representative for assistance.

### 7.2 **Obtaining Service**

---

To obtain information concerning factory service, contact Newport Corporation or your Newport representative. Please have the following information available:

1. Instrument model number (On front panel)
2. Instrument serial number (On rear panel)
3. Description of the problem.

If the instrument is to be returned to Newport Corporation, you will be given a Return Materials Authorization (RMA) number, which you should reference in your shipping documents as well as clearly marked on the outside of the shipping container.

Please fill out the service form, located on the following page, and have the information ready when contacting Newport Corporation. Return the completed service form with the instrument.



# Service Form

## Newport Corporation

USA Office: 949/863-3144

FAX: 949/253-1800

Name \_\_\_\_\_

RETURN AUTHORIZATION # \_\_\_\_\_

Company \_\_\_\_\_

(Please obtain prior to return of item)

Address \_\_\_\_\_

Country \_\_\_\_\_

Date \_\_\_\_\_

P.O. Number \_\_\_\_\_

Phone Number \_\_\_\_\_

### Item(s) being returned:

Model # \_\_\_\_\_ Serial # \_\_\_\_\_

Description \_\_\_\_\_

Reason for return of goods (please list any specific problems) \_\_\_\_\_

\_\_\_\_\_

List all control settings and describe problem \_\_\_\_\_

\_\_\_\_\_

\_\_\_\_\_ (Attach additional sheets as necessary)

Show a block diagram of your measurement system including all instruments connected (whether power is turned on or not). Describe signal source. If source is laser, describe output mode, peak power, pulse width, and repetition rate.

**Where is measurement being performed?**

(factory, controlled laboratory, out-of-doors, etc.) \_\_\_\_\_

What power line voltage is used? \_\_\_\_\_ Variation? \_\_\_\_\_

Frequency? \_\_\_\_\_ Ambient Temperature? \_\_\_\_\_

Any additional information. (If special modifications have been made by the user, please describe below)

---

---

---



## 8. Error Messages

### 8.1 Introduction

---

Error messages may appear on the display when error conditions occur in the respective functions of the 8000. For example, a current limit error in the TEC module will be displayed.

In remote operation, the current error list can be read by issuing the "ERR?" query. When this is done, a string will be returned containing all of the error messages which are currently in the error message queue.

The errors codes are numerically divided into areas of operation as shown below.

<u>Error Code Range</u>	<u>Area of Operation</u>
E-001 to E-099	Internal Program Errors
E-100 to E-199	Parser Errors
E-200 to E-299	Execution Control Errors
E-300 to E-399	GPIB/RS232 Errors
E-400 to E-499	TEC Control Errors
E-500 to E-599	Laser Control Errors

Table 12 contains all of the error messages which may be generated by the 8000. Not all of these messages may be displayed. Some refer to GPIB activities only, for example.

**Table 12 - Error Codes**

<u>Error Code</u>	<u>Explanation</u>
E-001	Memory allocation failure.
E-002	Floating point error
E-101	<program mnemonic> is too long.
E-102	<PROGRAM MESSAGE UNIT> is too long.
E-103	<DEFINITE LENGTH ARBITRARY BLOCK PROGRAM DATA> length too long.
E-104	<NON-DECIMAL NUMERIC PROGRAM DATA> type not defined.
E-105	<DECIMAL PROGRAM DATA> exponent not valid.
E-106	<DECIMAL PROGRAM DATA> digit expected
E-107	<DECIMAL PROGRAM DATA> digit not expected.
E-108	<DECIMAL PROGRAM DATA> more than one decimal point.

<b><u>Error Code</u></b>	<b><u>Explanation</u></b>
E-109	<DECIMAL PROGRAM DATA> more than exponential indicator (E).
E-110	<SUFFIX PROGRAM DATA> must have digit following sign.
E-111	<SUFFIX PROGRAM DATA> must have character following operator.
E-113	<ARBITRARY BLOCK PROGRAM DATA> less than digit count.
E-114	<DEFINITE LENGTH BLOCK PROGRAM DATA> premature end of data.
E-115	<PLACEHOLDER PROGRAM DATA> identifier not valid.
E-116	Parser syntax error, character was not expected.
E-120	<program mnemonic> Lookup, word as part of a header path, has no commands.
E-121	<program mnemonic> Lookup, word as part of a header path, is not found.
E-122	<program mnemonic> Lookup, cannot find a null entry.
E-123	<program mnemonic> Lookup, word within context of current path, is not found.
E-124	<program mnemonic> Lookup, failed because query/command type match failed.
E-125	<program mnemonic> Lookup, word within context of common command path, is not found.
E-126	Too few or too many program data elements.
E-201	<PROGRAM DATA> value out of range.
E-202	<PROGRAM DATA> will not convert to valid type.
E-203	Security violation, command is not available without clearance.
E-204	<PROGRAM DATA> suffix type is not valid.
E-205	<PROGRAM DATA> is not a Boolean value or word.
E-206	<PROGRAM DATA> will not convert to a signed 16-byte value.
E-207	<PROGRAM DATA> will not convert to an unsigned 16-byte value.
E-208	<PROGRAM DATA> will not convert to a signed 32-byte value.
E-209	<PROGRAM DATA> will not convert to an unsigned 32-byte value.
E-210	<PROGRAM DATA> will not convert to a floating point value.

---

<u>Error Code</u>	<u>Explanation</u>
E-211	<PROGRAM DATA> will not convert to a character value.
E-212	<PROGRAM DATA> will not convert to a byte array pointer.
E-213	<PROGRAM DATA> is incorrect block data length.
E-214	<PROGRAM DATA> length exceeds maximum.
E-216	Present configuration has changed from last stored configuration.
E-217	Attempted to recall a bin from a unsaved position.
E-301	A <RESPONSE MESSAGE> was ready, but controller failed to read it. (Query error).
E-302	6000 is talker, but controller didn't read entire message.
E-303	Input buffer overflow
E-304	Output buffer overflow
E-305	Parser buffer overflow
E-402	Sensor open disabled output.
E-403	TEC module open disabled output.
E-404	TEC Current limit disabled output.
E-405	TEC Voltage limit disabled output.
E-406	TEC resistance/reference limit disabled output
E-407	TEC high temperature limit disabled output.
E-409	Sensor change disabled output.
E-410	TEC out of tolerance disabled output.
E-411	TEC control error disabled output.
E-412	Analog section status is all 1's or all 0's (power down).
E-413	Serial EPROM checksum error.
E-415	Sensor short disabled output.
E-416	Incorrect Configuration for Calibration Sequence to start.
E-417	TEC output must be on to begin calibration.
E-418	TEC C1, C2, or C3 constants are bad, all set to default values.
E-431	TEC link condition forced output on
E-432	TEC link condition forced output off
E-433	Attempt to select non-TEC channel for TEC mode.
E-501	Laser interlock disabled output.
E-502	Laser hard current limit disabled output
E-503	Laser open circuit disabled output.

<b><u>Error Code</u></b>	<b><u>Explanation</u></b>
E-504	Laser current limit disabled output.
E-505	Laser voltage limit disabled output.
E-506	Laser photodiode current limit disabled output
E-507	Laser photodiode power limit disabled output.
E-508	TEC link disabled laser.
E-509	Laser short circuit disabled output
E-510	Laser out of tolerance disabled output.
E-511	Laser control error disabled output.
E-512	Analog section status is all 1's or 0's (power down).
E-513	Serial EPROM checksum error.
E-514	Laser mode change disabled output
E-515	Laser bandwidth change disabled output
E-516	Incorrect Configuration for Calibration Sequence to start.
E-517	Calibration for Laser Diode current must have the output on to start.
E-518	Calibration for the Monitor Diode must have the output on and the sensitivity set to zero to start.
E-519	Setting a measurement is only valid during the calibration phase for that measurement. User has tried to calibrate a measurement without first entering the required calibration mode.
E-520	User cannot change the Laser Current set point while operating in a calibration mode for another measurement.
E-531	Laser link condition forced output on
E-532	Laser link condition forced output off
E-533	Attempted to select non-laser channel for laser operation.
E-900	Calculation Error shutdown output
E-901	System over temperature shutdown all outputs
E-902	Front laser enable panel key lock in off position, shutdown all laser outputs
E-903	Loading of a saved bin shutdown module output

# 9. Specifications

## 9.1 Model 8000 Modules

---

### 9.1.1 8540M MOPA Laser Diode Driver Module

<u>Specifications</u>	<u>Oscillator</u>	<u>Amplifier</u>
<b>Laser Output</b>		
Output Current Range (mA)	0 to 500 mA	0 to 4,000 mA
Output Current Resolution (mA)	0.0076	0.0610
Output Current Accuracy <sup>1</sup>	0.03 + 15 $\mu$ A	0.03 + 120 $\mu$ A
Compliance Voltage	5 Volts	5 Volts
Temperature Coefficient (Full Scale)	< 50 ppm/°C	< 50 ppm/°C
Short Term Stability (1 hr., Full Scale)	< 10 ppm	< 10 ppm
Long Term Stability (24 hr., Full Scale)	< 50 ppm	< 50 ppm
Noise/Ripple (rms) <sup>2</sup>	< 4.0 $\mu$ A	< 10 $\mu$ A
<b>Current Limit</b>		
Range	0 to 500 mA	0 to 4,000 mA
Resolution	1 mA	1 mA
Accuracy	$\pm$ 2 mA	$\pm$ 5 mA
<b>Analog Modulation<sup>3</sup></b>		
Input range, Input Impedance	0 to 10V, 10k $\Omega$	0 to 10V, 10k $\Omega$
Transfer Function	50 mA/V	400 mA/V
Bandwidth (3 dB $\pm$ 10%)	DC to 500 kHz	DC to 100 kHz
Midband Crosstalk	> 40 dB below Amplifier Signal	> 10 dB below Oscillator Signal
<b>Photodiode Input</b>		
Temperature Coefficient (% Full Scale/°C)	N/A	< 0.02
Range	N/A	0 - 20 mA
Stability (Full Scale, 24 hours)	N/A	$\pm$ 0.02 %
Accuracy <sup>1</sup>	N/A	0.004 + 1 $\mu$ A
Photodiode Reverse Bias ( $\pm$ 10%)	N/A	5 Volts
<b>Measurement Display</b>		
Output Current Range (mA)	0 to 500.00	0 to 4,000.0
Output Current Resolution (mA)	0.01	0.1
Output Current Accuracy <sup>1</sup>	0.02 + 20 $\mu$ A	0.02 + 200 $\mu$ A
Forward Voltage Range (Volts)	0.000 to 5.000	0.000 to 5.000
Forward Voltage Resolution (mV)	0.1	0.1
Forward Voltage Accuracy <sup>1</sup>	0.005 + 0.3 mV	0.005 + 0.3 mV
Photodiode Current Range ( $\mu$ A)	N/A	15 - 20,000
Photodiode Current Resolution ( $\mu$ A)	N/A	0.1
Photodiode Current Accuracy <sup>1</sup>	N/A	0.01 + 1 $\mu$ A
PD Resp. Range ( $\mu$ A/mW)	N/A	0.00 to 600.00
PD Resp. Resolution ( $\mu$ A/mW)	N/A	0.01
Optical Power Range (mW)	N/A	0.00 to 4000.0

---

<sup>1</sup>  $\pm$  (% reading + fixed error)

<sup>2</sup> True RMS, 3Hz to 300 kHz,  $\frac{1}{2}$  full scale, resistive load

<sup>3</sup> Modulation input can be switched in setup screen to either master oscillator or power amplifier section - only one section can be modulated at a time.

Optical Power Resolution (mW)      N/A      0.01

## 9.1.2 Temperature Controller (TEC) / Dual (TEC) Module Specifications

<u>Specifications</u>	<u>8350</u>	<u>8325D (Dual)</u>
<b>TEC Output</b>		
Maximum Current	5 Amps	2.5 Amps
Maximum Voltage	8 Volts	6 Volts
Typical Power	40 Watts	15 Watts
TE Current Resolution (mA)	0.153	0.076
TE Current Accuracy (mA)	← ± (0.02 % set point + 4 mA) →	
<b>Current Limit</b>		
Range	0 to 5 Amps	0 to 2.5 Amps
Accuracy	± 20 mA	± 10 mA
Ripple/Noise (rms)	< 1 mA	< 1 mA
Short Term Stability (1 hour, 30°C)	← 17 ppm →	← 17 ppm →
Long Term Stability (24 hour, 30°C)	← 33 ppm →	← 33 ppm →
Temperature Coefficient (°C/°C)	< 0.05	< 0.05
<b>Display</b>		
<b>Range</b>		
Temperature	-100.00°C to +240.00°C	-100.00°C to +240.00°C
Resistance (10 μA)	0.01 kΩ to 495.000 kΩ	0.01 kΩ to 495.000 kΩ
Resistance (100 μA)	0.001 kΩ to 49.500 kΩ	0.001 kΩ to 49.500 kΩ
Resistance (RTD)	20 Ω to 192 Ω	N/A
LM335 Voltage	2331 mV to 3731 mV	N/A
AD590 Current	248.15 μA to 378.15 μA	N/A
TE Current	± 5.00 Amps	± 2.50 Amps
<b>Resolution</b>		
Temperature	0.01°C	0.01°C
Resistance (10 μA)	10 Ω	10 Ω
Resistance (100 μA)	1 Ω	1 Ω
Resistance (RTD)	0.01 Ω	N/A
LM335 Voltage	0.1 mV	N/A
AD590 Current	0.01 μA	N/A
TE Current	1 mA	1 mA
<b>Accuracy<sup>4</sup></b>		
Temperature	± 0.1 °C	± 0.1 °C
Resistance (10 μA)	← ± (0.04% + 16 Ω) →	← ± (0.04% + 16 Ω) →
Resistance (100 μA)	← ± (0.05% + 8 Ω) →	← ± (0.05% + 8 Ω) →
Resistance (RTD)	± (0.03% + 50 mΩ)	N/A
LM335 Voltage	± (0.09% + 1 mV)	N/A
AD590 Current	± (0.005% + 0.5 uA)	N/A
TE Current	← ± (0.09% + 2 mA) →	← ± (0.09% + 2 mA) →

<sup>4</sup> ± (% of reading + fixed error)

Temperature Sensors	Thermistor	AD590	LM335	RTD (100 $\Omega$ ) <sup>5</sup>
Temp Control Resolution	0.01 °C	0.01 °C	0.01 °C	0.01 °C
Temp Control Accuracy	± 0.05 °C	± 0.05 °C	± 0.05 °C	± 0.05 °C
Sensor Bias Current or Voltage	10 $\mu$ A/100 $\mu$ A	+5 Volts	1 mA	1 mA

#### Temperature Calibration

Thermistor

$$1/T = (C1 \times 10^{-3}) + (C2 \times 10^{-4})(\ln R) + (C3 \times 10^{-7})(\ln R)^3$$

AD590

$$T = C1 + C2 \times (I_{AD590}/1\mu A/K - 273.15)$$

LM335

$$T = C1 + C2 \times (V_{LM335}/10mV/K - 273.15)$$

Pt RTD

$$R_t = R_o [ 1 + C1t + C2t^2 ] ; t \geq 0 \text{ } ^\circ\text{C},$$

$$R_t = R_o [ 1 + C1t + C2t^2 + C3t^3(t - 100) ] ; t < 0 \text{ } ^\circ\text{C}$$

$R_o$  = resistance at 0 °C, where  $R_o=100\Omega$  for a 100 $\Omega$  Pt RTD.

<sup>5</sup> Accuracy is with lead wire resistance calibrated out.

### 9.1.3 Laser Diode Driver (LDD) Modules

<u>Specifications</u>	<u>8505</u>	<u>8510</u>	<u>8530</u>	<u>8560</u>
<b>Laser Output</b>				
Output Current Range (mA) <sup>6</sup>	0 to 500 mA	0 to 1,000 mA	0 to 3,000 mA	0 to 6,000 mA
Output Current Resolution (mA) (16-bit)	0.0076	0.0153	0.0458	0.0916
Output Current Accuracy <sup>7</sup>	0.03 + 15 $\mu$ A	0.03 + 30 $\mu$ A	0.03 + 90 $\mu$ A	0.03 + 180 $\mu$ A
Compliance Voltage	7 Volts	5 Volts	5 Volts	5 Volts
Temperature Coefficient (Full Scale)	< 50 ppm/ $^{\circ}$ C	< 50 ppm/ $^{\circ}$ C	< 50 ppm/ $^{\circ}$ C	< 50 ppm/ $^{\circ}$ C
Short Term Stability (1 hr., Full Scale)	< 10 ppm	< 10 ppm	< 10 ppm	< 10 ppm
Long Term Stability (24 hr., Full Scale)	< 50 ppm	< 50 ppm	< 50 ppm	< 50 ppm
Noise/Ripple (rms)				
Hi BW	< 8.0 $\mu$ A	< 10 $\mu$ A	< 15 $\mu$ A	< 25 $\mu$ A
Lo BW	< 4.0 $\mu$ A	< 8.0 $\mu$ A	< 10 $\mu$ A	< 20 $\mu$ A
Lo BW - CW	< 2.0 $\mu$ A	< 2.5 $\mu$ A	< 6 $\mu$ A	< 17 $\mu$ A
<b>Current Limit</b>				
Range	0 to 500 mA	0 to 1,000 mA	0 to 3,000 mA	0 to 6,000 mA
Resolution	1 mA	1 mA	1 mA	1 mA
Accuracy	$\pm$ 2 mA	$\pm$ 2 mA	$\pm$ 4 mA	$\pm$ 6 mA
<b>Analog Modulation</b>				
Input range, Input Impedance	0 to 10V, 10k $\Omega$	0 to 10V, 10k $\Omega$	0 to 10V, 10k $\Omega$	0 to 10V, 10k $\Omega$
Transfer Function	50 mA/V	100 mA/V	300 mA/V	600 mA/V
Bandwidth (3 dB)				
Hi BW	DC to 350 kHz	DC to 250 kHz	DC to 100 kHz	DC to 100 kHz
Lo BW	DC to 10 kHz	DC to 10 kHz	DC to 10 kHz	DC to 10 kHz
Lo BW - CW	DC to 30 Hz	DC to 30 Hz	DC to 30 Hz	DC to 30 Hz
<b>Photodiode Input / Monitor Current</b>				
Temperature Coefficient (% Full Scale/ $^{\circ}$ C)	< 0.02	< 0.02	< 0.02	< 0.02
Range	0 - 5 mA	0 - 5 mA	0 - 20 mA	0 - 20 mA
Stability (Full Scale, 24 hours)	$\pm$ 0.02 %	$\pm$ 0.02 %	$\pm$ 0.02 %	$\pm$ 0.02 %
Accuracy <sup>7</sup>	0.004 + 0.5 $\mu$ A	0.004 + 0.5 $\mu$ A	0.004 + 1 $\mu$ A	0.004 + 1 $\mu$ A
Photodiode Reverse Bias ( $\pm$ 10%)	0 to 5 Volts	0 to 5 Volts	0 to 5 Volts	0 to 5 Volts
<b>Measurement Display</b>				
Output Current Range (mA)	0 to 500.00	0 to 1,000.0	0 to 3,000.0	0 to 6,000.0
Output Current Resolution (mA)	0.01	0.1	0.1	0.1
Output Current Accuracy <sup>7</sup>	0.02 + 20 $\mu$ A	0.02 + 200 $\mu$ A	0.02 + 200 $\mu$ A	0.02 + 200 $\mu$ A
Forward Voltage Range (Volts)	0.000 to 7.000	0.000 to 5.000	0.000 to 5.000	0.000 to 5.000
Forward Voltage Resolution (mV)	0.1	0.1	0.1	0.1
Forward Voltage Accuracy <sup>7</sup>	0.005 + 0.3 mV	0.005 + 0.3 mV	0.005 + 0.3 mV	0.005 + 0.3 mV
Photodiode Current Range ( $\mu$ A)	5 - 5,000	5 - 5,000	15 - 20,000	15 - 20,000
Photodiode Current Resolution ( $\mu$ A)	0.1	0.1	0.1	0.1
Photodiode Current Accuracy <sup>7</sup>	0.01 + 0.5 $\mu$ A	0.01 + 0.5 $\mu$ A	0.01 + 1 $\mu$ A	0.01 + 1 $\mu$ A
PD Resp. Range ( $\mu$ A/mW)	0.00 to 600.00	0.00 to 600.00	0.00 to 600.00	0.00 to 600.00
PD Resp. Resolution ( $\mu$ A/mW)	0.01	0.01	0.01	0.01
Optical Power Range (mW)	0.00 to 500.00	0.00 to 1000.0	0.00 to 3000.0	0.00 to 6000.0
Optical Power Resolution (mW)	0.01	0.01	0.01	0.01

<sup>6</sup> Other current ranges are available upon request - please consult with factory.

<sup>7</sup>  $\pm$  (% reading + fixed error)



### 9.1.4 Dual Laser Diode Driver (LDD) Modules

<b>Specifications</b>	<b>8501D</b>	<b>8505D</b>	<b>8510D</b>
<b>Laser Output</b>			
Output Current Range (mA)	0 to 100 mA	0 to 500 mA	0 to 1,000 mA
Output Current Resolution (mA) (16-bit)	0.0015	0.0076	0.0153
Output Current Accuracy <sup>9</sup>	0.03 + 5 $\mu$ A	0.03 + 15 $\mu$ A	0.03 + 30 $\mu$ A
Compliance Voltage	5 Volts	5 Volts	5 Volts
Temperature Coefficient (Full Scale)	< 50 ppm/ $^{\circ}$ C	< 50 ppm/ $^{\circ}$ C	< 50 ppm/ $^{\circ}$ C
Short Term Stability (1 hr., Full Scale)	< 10 ppm	< 10 ppm	< 10 ppm
Long Term Stability (24 hr., Full Scale)	< 50 ppm	< 50 ppm	< 50 ppm
Noise/Ripple (rms) <sup>8</sup>	< 2 $\mu$ A	< 2 $\mu$ A	< 2.5 $\mu$ A
<b>Current Limit</b>			
Range	0 to 100 mA	0 to 500 mA	0 to 1,000 mA
Resolution	1 mA	1 mA	1 mA
Accuracy	$\pm$ 2 mA	$\pm$ 2 mA	$\pm$ 2 mA
<b>Photodiode Input</b>			
Range	0 - 5 mA	0 - 5 mA	0 - 5 mA
Stability (Full Scale, 24 hours)	$\pm$ 0.02 %	$\pm$ 0.02 %	$\pm$ 0.02 %
Accuracy <sup>9</sup>	0.004 + 0.5 $\mu$ A	0.004 + 0.5 $\mu$ A	0.004 + 0.5 $\mu$ A
Temperature Coefficient (% Full Scale/ $^{\circ}$ C)	< 0.02	< 0.02	< 0.02
Photodiode Reverse Bias	none	none	none
<b>Measurement Display</b>			
Output Current Range (mA)	0 to 100.00	0 to 500.0	0 to 1,000.0
Output Current Resolution (mA)	0.01	0.01	0.1
Output Current Accuracy <sup>9</sup>	0.02 + 10 $\mu$ A	0.02 + 20 $\mu$ A	0.02 + 200 $\mu$ A
Forward Voltage Range (Volts)	0.000 to 5.000	0.000 to 5.000	0.000 to 5.000
Forward Voltage Resolution (mV)	0.1	0.1	0.1
Forward Voltage Accuracy <sup>9</sup>	0.005 + 0.3 mV	0.005 + 0.3 mV	0.005 + 0.3 mV
Photodiode Current Range ( $\mu$ A)	5 - 5,000	5 - 5,000	5 - 5,000
Photodiode Current Resolution ( $\mu$ A)	0.1	0.1	0.1
Photodiode Current Accuracy <sup>9</sup>	0.01 + 0.5 $\mu$ A	0.01 + 0.5 $\mu$ A	0.01 + 0.5 $\mu$ A
PD Resp. Range ( $\mu$ A/mW)	0.00 to 600.00	0.00 to 600.00	0.00 to 600.00
PD Resp. Resolution ( $\mu$ A/mW)	0.01	0.01	0.01
Optical Power Range (mW)	0.00 to 100.00	0.00 to 500.0	0.00 to 1000.0
Optical Power Resolution (mW)	0.01	0.01	0.01

<sup>8</sup> True rms, 3Hz to 300 kHz, 1/2 FS, resistive load

<sup>9</sup>  $\pm$  (% reading + fixed error)

### 9.1.5 Combo Module, Laser Diode Driver (LDD) Section

<b>Specifications</b>	<b>8605</b>	<b>8610</b>	<b>8630</b>
<b>Laser Output</b>			
Output Current Range (mA) <sup>10</sup>	0 to 500 mA	0 to 1,000 mA	0 to 3,000 mA
Output Current Resolution (mA) (16-bit)	0.0076	0.0153	0.0458
Output Current Accuracy <sup>12</sup>	0.03 + 15 $\mu$ A	0.03 + 30 $\mu$ A	0.03 + 90 $\mu$ A
Compliance Voltage	7 Volts	7 Volts	5 Volts
Temperature Coefficient (Full Scale)	< 50 ppm/°C	< 50 ppm/°C	< 50 ppm/°C
Short Term Stability (1 hr., Full Scale)	< 10 ppm	< 10 ppm	< 10 ppm
Long Term Stability (24 hr., Full Scale)	< 50 ppm	< 50 ppm	< 50 ppm
Noise/Ripple (rms) <sup>11</sup>	< 2 $\mu$ A	< 5 $\mu$ A	< 6 $\mu$ A
<b>Current Limit</b>			
Range	0 to 500 mA	0 to 1,000 mA	0 to 3,000 mA
Resolution	1 mA	1 mA	1 mA
Accuracy	$\pm$ 2 mA	$\pm$ 2 mA	$\pm$ 4 mA
<b>Internal Function Generator</b>			
Waveforms	Sine and square wave	Sine and square wave	Sine and square wave
Frequency Range 1	200 Hz to 2 kHz	200 Hz to 2 kHz	200 Hz to 2 kHz
Frequency Range 2	2 kHz to 300 kHz	2 kHz to 300 kHz	2 kHz to 300 kHz
Squarewave Duty Cycle ( $\pm$ 5%)	50%	50%	50%
Independent Output Set-Points	$I_{max}$ , $I_{min}$	$I_{max}$ , $I_{min}$	$I_{max}$ , $I_{min}$
Frequency Jitter	< 1% rms	< 1% rms	< 1% rms
Frequency Accuracy	$\pm$ 5 %	$\pm$ 5 %	$\pm$ 5 %
Amplitude Accuracy	$\pm$ 5 %	$\pm$ 5 %	$\pm$ 5 %
Sinewave Total Harmonic Distortion	< 2 %	< 2 %	< 2 %
Squarewave risetime	< 500 ns	< 500 ns	< 500 ns
Optional Sync. Out TTL/CMOS level	{	Sine and square: zero-crossing sync.	}
<b>Photodiode Input</b>			
Range	0 - 5 mA	0 - 5 mA	0 - 20 mA
Stability (Full Scale, 24 hours)	$\pm$ 0.02 %	$\pm$ 0.02 %	$\pm$ 0.02 %
Accuracy <sup>12</sup>	0.004 + 0.5 $\mu$ A	0.004 + 0.5 $\mu$ A	0.004 + 1 $\mu$ A
Temperature Coefficient (% Full Scale/°C)	< 0.02	< 0.02	< 0.02
Photodiode Reverse Bias ( $\pm$ 10%)	0 to 5 Volts (user specified)	0 to 5 Volts (user specified)	0 to 5 Volts (user specified)
<b>Measurement Display</b>			
Output Current Range (mA)	0 to 500.0	0 to 1,000.0	0 to 3,000.00
Output Current Resolution (mA)	0.01	0.1	0.1
Output Current Accuracy <sup>12</sup>	0.02 + 20 $\mu$ A	0.02 + 200 $\mu$ A	0.02 + 200 $\mu$ A
Forward Voltage Range (Volts)	0.000 to 7.000	0.000 to 7.000	0.000 to 5.000
Forward Voltage Resolution (mV)	0.1	0.1	0.1
Forward Voltage Accuracy <sup>12</sup>	0.005 + 0.3 mV	0.005 + 0.3 mV	0.005 + 0.3 mV
Photodiode Current Range ( $\mu$ A)	5 - 5,000	5 - 5,000	15 - 20,000
Photodiode Current Resolution ( $\mu$ A)	0.1	0.1	0.1
Photodiode Current Accuracy <sup>12</sup>	0.01 + 0.5 $\mu$ A	0.01 + 0.5 $\mu$ A	0.01 + 1 $\mu$ A
PD Resp. Range ( $\mu$ A/mW)	0.00 to 600.00	0.00 to 600.00	0.00 to 600.00
PD Resp. Resolution ( $\mu$ A/mW)	0.01	0.01	0.01

<sup>10</sup> Other current ranges are available upon request - please consult with factory.

<sup>11</sup> True rms, 3 Hz to 300 kHz, 1/2 FS, resistive load, modulation disabled

<sup>12</sup>  $\pm$  (% reading + fixed error)

---

Optical Power Range (mW)	0.00 to 500.0	0.00 to 1000.0	0.00 to 3,000.00
Optical Power Resolution (mW)	0.01	0.01	0.01

### 9.1.5.1 Combo Module, TEC Section

#### Specifications

#### 86xx

#### TEC Output

Maximum Current	2.5 Amps
Maximum Voltage	6 Volts
Typical Power	15 Watts

#### Current Limit

Range	0 to 2.5 Amps
Accuracy	± 10 mA

Ripple/Noise (rms)	< 1 mA
Short Term Stability (1 hour) (30°C)	< 17 ppm
Long Term Stability (24 hour) (30°C)	< 33 ppm
Temperature Coefficient (°C/°C)	0.05

#### Measurement Display

#### Range

Temperature	-100.00°C to +240.00°C
Resistance (10 µA)	0.01 kΩ to 495 kΩ
Resistance (100 µA)	0.001 kΩ to 49.5 kΩ
TE Current	± 2.50 Amps

#### Resolution

Temperature	0.01°C
Resistance (10 µA)	10 Ω
Resistance (100 µA)	1 Ω
TE Current	1 mA

#### Accuracy<sup>13</sup>

Temperature <sup>14</sup>	± 0.1 °C
Resistance (10 µA)	± (0.04% + 16 Ω)
Resistance (100 µA)	± (0.05% + 8 Ω)
TE Current	± (0.3% + 2 mA)

#### Temperature Sensor

Sensor Type	NTC, 2-wire Thermistor
Sensor Bias	10 µA/100 µA
Thermistor Calibration	$1/T = (C1 \times 10^{-3}) + (C2 \times 10^{-4})(\ln R) + (C3 \times 10^{-7})(\ln R)^3$

<sup>13</sup> ± (% of reading + fixed error)

<sup>14</sup> Temperature is a value derived from using the thermistor calibration equation. Accuracy can be computed by applying the sensor's resistance parameter to the above equation at the temperature in question.

## 9.2 Model 8008 Modules

### 9.2.1 Dual Laser Diode Driver (LDD) Modules

<u>Specifications</u>	<u>8501.8D</u>	<u>8505.8D</u>	<u>8510.8D</u>
<b>Laser Output</b>			
Output Current Range (mA)	0 to 100 mA	0 to 500 mA	0 to 1,000 mA
Output Current Resolution (mA) (16-bit)	0.0015	0.0076	0.0153
Output Current Accuracy <sup>16</sup>	0.03 + 5 $\mu$ A	0.03 + 15 $\mu$ A	0.03 + 30 $\mu$ A
Compliance Voltage	3 Volts	3 Volts	3 Volts
Temperature Coefficient (Full Scale)	< 50 ppm/°C	< 50 ppm/°C	< 50 ppm/°C
Short Term Stability (1 hr., Full Scale)	< 10 ppm	< 10 ppm	< 10 ppm
Long Term Stability (24 hr., Full Scale)	< 50 ppm	< 50 ppm	< 50 ppm
Noise/Ripple (rms) <sup>15</sup>	< 2 $\mu$ A	< 2 $\mu$ A	< 2.5 $\mu$ A
<b>Current Limit</b>			
Range	0 to 100 mA	0 to 500 mA	0 to 1,000 mA
Resolution	1 mA	1 mA	1 mA
Accuracy	$\pm$ 2 mA	$\pm$ 2 mA	$\pm$ 2 mA
<b>Photodiode Input</b>			
Range	0 - 5 mA	0 - 5 mA	0 - 5 mA
Stability (Full Scale, 24 hours)	$\pm$ 0.02 %	$\pm$ 0.02 %	$\pm$ 0.02 %
Accuracy <sup>16</sup>	0.004 + 0.5 $\mu$ A	0.004 + 0.5 $\mu$ A	0.004 + 0.5 $\mu$ A
Temperature Coefficient (% Full Scale/°C)	< 0.02	< 0.02	< 0.02
Photodiode Reverse Bias	none	none	none
<b>Measurement Display</b>			
Output Current Range (mA)	0 to 100.00	0 to 500.0	0 to 1,000.0
Output Current Resolution (mA)	0.01	0.01	0.1
Output Current Accuracy <sup>16</sup>	0.02 + 10 $\mu$ A	0.02 + 20 $\mu$ A	0.02 + 200 $\mu$ A
Forward Voltage Range (Volts)	0.000 to 3.000	0.000 to 3.000	0.000 to 3.000
Forward Voltage Resolution (mV)	0.1	0.1	0.1
Forward Voltage Accuracy <sup>16</sup>	0.005 + 0.3 mV	0.005 + 0.3 mV	0.005 + 0.3 mV
Photodiode Current Range ( $\mu$ A)	5 - 5,000	5 - 5,000	5 - 5,000
Photodiode Current Resolution ( $\mu$ A)	0.1	0.1	0.1
Photodiode Current Accuracy <sup>16</sup>	0.01 + 0.5 $\mu$ A	0.01 + 0.5 $\mu$ A	0.01 + 0.5 $\mu$ A
PD Resp. Range ( $\mu$ A/mW)	0.00 to 600.00	0.00 to 600.00	0.00 to 600.00
PD Resp. Resolution ( $\mu$ A/mW)	0.01	0.01	0.01
Optical Power Range (mW)	0.00 to 100.00	0.00 to 500.00	0.00 to 1000.0
Optical Power Resolution (mW)	0.01	0.01	0.01

<sup>15</sup> True rms, 3Hz to 300 kHz, 1/2 FS, resistive load

<sup>16</sup>  $\pm$  (% reading + fixed error)

## 9.2.2 Combo Module, Laser Diode Driver (LDD) Section

Specifications	8601.8C	8605.8C	8610.8C
<b>Laser Output</b>			
Output Current Range (mA)	0 to 100 mA	0 to 500 mA	0 to 1,000 mA
Output Current Resolution (mA) (16-bit)	0.0015	0.0076	0.0153
Output Current Accuracy <sup>18</sup>	0.03 + 5 $\mu$ A	0.03 + 15 $\mu$ A	0.03 + 30 $\mu$ A
Compliance Voltage	3 Volts	3 Volts	3 Volts
Temperature Coefficient (Full Scale)	< 50 ppm/ $^{\circ}$ C	< 50 ppm/ $^{\circ}$ C	< 50 ppm/ $^{\circ}$ C
Short Term Stability (1 hr., Full Scale)	< 10 ppm	< 10 ppm	< 10 ppm
Long Term Stability (24 hr., Full Scale)	< 50 ppm	< 50 ppm	< 50 ppm
Noise/Ripple (rms) <sup>17</sup>	< 2 $\mu$ A	< 2 $\mu$ A	< 5 $\mu$ A
<b>Current Limit</b>			
Range	0 to 100 mA	0 to 500 mA	0 to 1,000 mA
Resolution	1 mA	1 mA	1 mA
Accuracy	$\pm$ 2 mA	$\pm$ 2 mA	$\pm$ 2 mA
<b>Internal Function Generator</b>			
Waveforms	Sine & square wave	Sine & square wave	Sine & square wave
Frequency Range 1	200 Hz to 2 kHz	200 Hz to 2 kHz	200 Hz to 2 kHz
Frequency Range 2	2 kHz to 300 kHz	2 kHz to 300 kHz	2 kHz to 300 kHz
Squarewave Duty Cycle ( $\pm$ 5%)	50%	50%	50%
Independent Output Set-Points	$I_{max}$ , $I_{min}$	$I_{max}$ , $I_{min}$	$I_{max}$ , $I_{min}$
Frequency Jitter	< 1% rms	< 1% rms	< 1% rms
Frequency Accuracy	$\pm$ 5 %	$\pm$ 5 %	$\pm$ 5 %
Amplitude Accuracy	$\pm$ 5 %	$\pm$ 5 %	$\pm$ 5 %
Sinewave Total Harmonic Distortion	< 2 %	< 2 %	< 2 %
Squarewave risetime	< 500 ns	< 500 ns	< 500 ns
Optional Sync. Out TTL/CMOS level	{	Sine: zero-crossing sync. Square: zero-crossing sync.	}
<b>Photodiode Input</b>			
Range	0 - 5 mA	0 - 5 mA	0 - 5 mA
Stability (Full Scale, 24 hours)	$\pm$ 0.02 %	$\pm$ 0.02 %	$\pm$ 0.02 %
Accuracy <sup>18</sup>	0.004 + 0.5 $\mu$ A	0.004 + 0.5 $\mu$ A	0.004 + 0.5 $\mu$ A
Temperature Coefficient (% Full Scale/ $^{\circ}$ C)	< 0.02	< 0.02	< 0.02
Photodiode Reverse Bias ( $\pm$ 10%)	0 to 5 Volts (user specified)	0 to 5 Volts (user specified)	0 to 5 Volts (user specified)
<b>Measurement Display</b>			
Output Current Range (mA)	0 to 100.00	0 to 500.0	0 to 1,000.0
Output Current Resolution (mA)	0.01	0.01	0.1
Output Current Accuracy <sup>18</sup>	0.02 + 10 $\mu$ A	0.02 + 20 $\mu$ A	0.02 + 200 $\mu$ A
Forward Voltage Range (Volts)	0.000 to 3.000	0.000 to 3.000	0.000 to 3.000
Forward Voltage Resolution (mV)	0.1	0.1	0.1
Forward Voltage Accuracy <sup>18</sup>	0.005 + 0.3 mV	0.005 + 0.3 mV	0.005 + 0.3 mV
Photodiode Current Range ( $\mu$ A)	5 - 5,000	5 - 5,000	5 - 5,000
Photodiode Current Resolution ( $\mu$ A)	0.1	0.1	0.1
Photodiode Current Accuracy <sup>18</sup>	0.01 + 0.5 $\mu$ A	0.01 + 0.5 $\mu$ A	0.01 + 0.5 $\mu$ A
PD Resp. Range ( $\mu$ A/mW)	0.00 to 600.00	0.00 to 600.00	0.00 to 600.00
PD Resp. Resolution ( $\mu$ A/mW)	0.01	0.01	0.01
Optical Power Range (mW)	0.00 to 100.00	0.00 to 500.00	0.00 to 1000.0

<sup>17</sup> True rms, 3 Hz to 300 kHz,  $\frac{1}{2}$  FS, resistive load, modulation disabled

<sup>18</sup>  $\pm$  (% reading + fixed error)

Optical Power Resolution (mW)	0.01	0.01	0.01
-------------------------------	------	------	------

### 9.2.2.1 Combo Module, TEC Section

#### Specifications

#### 86xx.8C

#### TEC Output

Maximum Current	2 Amps
Maximum Voltage	4 Volts
Typical Power	8 Watts

#### Current Limit

Range	0 to 2 Amps
Accuracy	± 10 mA

Ripple/Noise (rms)	< 1 mA
Short Term Stability (1 hour) (30°C)	< 17 ppm
Long Term Stability (24 hour) (30°C)	< 33 ppm
Temperature Coefficient (°C/°C)	0.05

#### Measurement Display

##### Range

Temperature	-100.00°C to +240.00°C
Resistance (10 µA)	0.01 kΩ to 495 kΩ
Resistance (100 µA)	0.001 kΩ to 49.5 kΩ
TE Current	± 2 Amps

##### Resolution

Temperature	0.01°C
Resistance (10 µA)	10 Ω
Resistance (100 µA)	1 Ω
TE Current	1 mA

##### Accuracy<sup>19</sup>

Temperature <sup>20</sup>	± 0.1 °C
Resistance (10 µA)	± (0.04% + 16 Ω)
Resistance (100 µA)	± (0.05% + 8 Ω)
TE Current	± (0.5% + 2 mA)

#### Temperature Sensor

Sensor Type	NTC, 2-wire Thermistor
Sensor Bias	10 µA/100 µA
Thermistor Calibration	$1/T = (C1 \times 10^{-3}) + (C2 \times 10^{-4})(\ln R) + (C3 \times 10^{-7})(\ln R)^3$

<sup>19</sup> ± (% of reading + fixed error)

<sup>20</sup> Temperature is a value derived from using the thermistor calibration equation. Accuracy can be computed by applying the sensor's resistance parameter to the above equation at the temperature in question.



### 9.3 Mainframe And General Specifications

Display	
Type	LCD graphics display, 240 (W) x 128 (H) pixels
Back Lighting	Green LED
Controls	Brightness and Contrast (contrast optimizes viewing angle)
Channel Active	Green LASER ACTIVE LED indicates that at least one Laser Diode output is on and the LCD graphics shows details of active channels.
Output Connectors	
Temperature Controller (TEC)	15-pin female D-sub
Dual Temperature Controller (TEC)	Two 15-pin female D-sub
Laser Diode Driver (LDD)	9-pin female D-sub, BNC (external Modulation), BNC (auxiliary photodiode input)
Dual Laser Diode Driver	Two 9-pin female D-sub
MOPA Laser Diode Driver	15-pin high density female D-sub , 9-pin male D-sub
Combination LDD/TEC	9-pin female D-sub (LDD), and 15-pin female D-sub (TEC)
Chassis Ground	4 mm Banana Jack
GPIB Connector	24 pin IEEE-488
RS232 Connector	One 9-pin male D-sub
Power Requirements	90 to 132 volts, 5 Amp Max.; 198 to 250 volts, 2.5 Amps Max. (user selectable), 50 to 60 Hz
Size (H x W x D)	133 mm x 426 mm x 356 mm (5.25 " x 16.75" x 14")
Mainframe Weight	14.3 kg (31.5 lbs.)
Modules Weight	1.1 kg (2.5 lbs.), typical weight each
Operating Temperature	0 to 40°C, < 70% relative humidity non-condensing
Storage Temperature	-20°C to 60°C, < 90% relative humidity non-condensing
Laser Safety Features	Laser Enable Key switch, Interlock, Output Delay (meets CDRH US21 CFR 1040.10). Interlock and output delay are part of the Laser Module.
Isolation	All modules electrically isolated with respect to each other and from earth ground.

In accordance with ongoing efforts to continuously improve our products, Newport Corporation reserves the right to modify product specifications without notice and without liability for such changes.